

SERVICE *and* TRAINING MANUAL

NAUTILUS ON DEMAND RV WATER HEATER



MODELS:
IW60A

FOR RECREATIONAL
VEHICLE USE ONLY

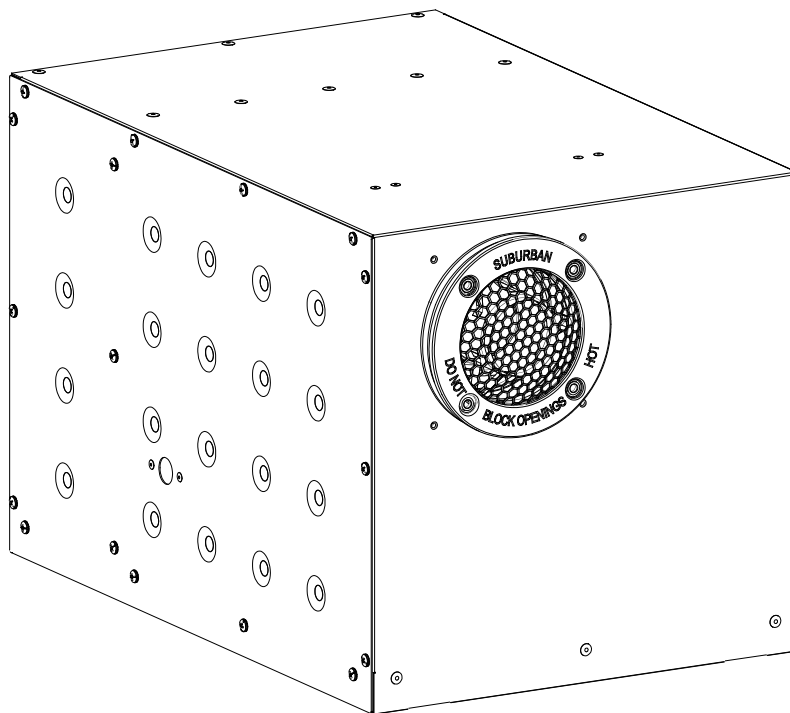

MANUFACTURED BY AIRXCEL, INC. - SUBURBAN DIVISION

Information published in this manual is subject to change without notice. | 02-06-2018

TABLE OF CONTENTS

TOPIC	PAGE
INTRODUCTION	3
SPECIFICATIONS	3
Unit Dimensions	3
INSTALLATION INSTRUCTIONS	
Installation Without Using Replacement Panel	4
Installation Using Replacement Panel	4
Making Electrical Connections	4
Installation of On Demand Control Center	4
Making Drain Connections	5
Making Water Connections	5
Making Gas Connections	5
OPERATING INSTRUCTIONS	
Operating Instructions using On Demand Control Center	5
Operating Faucets and Shower	5
Turning OFF the Nautilus On Demand Water Heater	5
SEQUENCE OF OPERATION	5
OPERATIONAL TROUBLESHOOTING	
No Water Flows from Faucet when Turned On	6
Burner Turns On, Temperature Fluctuates Erratically	6
On Demand Water Heater Comes On and Rapidly Cycles On and Off	6
Water Temperature is Too Low with Lower Water Flow	6
Water Temperature is Too High or No Temperature Control	6
Low Temperature Rise & Excessive Water Flow Required to Trigger the Nautilus	6
No Ignition	6
MAINTENANCE	
Draining and Storage Instructions	6
Winterizing	6
Freeze Protection	6
Descaling Information	6
Pressure Relief Valve	6
INSTALLATION INSTRUCTION ILLUSTRATIONS	7-13
SEQUENCE OF OPERATION ILLUSTRATION CHART	14
ERROR CODES AND MEANINGS	16
TROUBLESHOOTING GUIDE	17
INTERIOR VIEWS, REPLACEMENT PANELS, and VENT CAP ILLUSTRATIONS	21
EXPANDED VIEWS and REPLACEMENT PARTS LIST	22
TWO YEAR LIMITED WARRANTY	24

INTRODUCTION

This Service and Training Manual provided by the Suburban Products Factory Service Department is intended to be used by qualified service technicians only as a valuable tool in terms of product identification, troubleshooting and diagnosis of service issues, and as an outline for information concerning proper procedures for filing warranty service claims.

Included in this manual are product installation instructions, sequence of operation information, maintenance and service recommendations. Having an understanding of the appliance's sequence of operation and access to or knowledge of the wiring diagram are the cornerstones of proper diagnosis and troubleshooting. Other points of emphasis encompass the adherence to proper installation methods, voltage and gas pressure, and compliance to the physical installation tolerances and clearances. This manual is designed to assist service technicians in making the correct diagnosis efficiently.

Proper maintenance and service of an appliance is of the utmost importance. Failure to keep the appliance clean and well maintained is a significant contributing factor in the component breakdown and premature failure of the appliance.

SPECIFICATIONS

BTU/HR	15,000 MIN to 60,000 MAX
FUEL	ULP Gas (Propane)
INLET PRESSURE	MINIMUM 2.61kPa (10.5 INCHES W.C.) MAXIMUM 3.48 kPa (14 INCHES W.C.)
MANIFOLD PRESSURE	2.61 kPa (10.5 INCHES W.C.)
WATER OPERATING PRESSURE	MINIMUM: 206.8kPa (30 PSI) MAXIMUM: 1034.2kPa (150 PSI)
VOLTAGE	12 VDC NOMINAL; 10.5 VDC MINIMUM TO 14 VDC MAXIMUM
WATER FLOW REQUIREMENT	MINIMUM: 1.9 LPM (0.5 GPM) MAXIMUM: 5.7 LPM (1.5 GPM)
MINIMUM WIRING GAUGE	MINIMUM WIRING GAUGE 20 AWG 600V 105°F (Degrees Fahrenheit)
AMP DRAW	2.5 AMPS
RECOMMENDED FUSE SIZE	2 FUSES with 5 AMPS per FUSE

NAUTILUS (IW60A) ON DEMAND WATER HEATER DIMENSIONS

31.75cm H x 31.75cm W x 50.8cm D (12.5" H x 12.5" W x 20.0" D)

INSTALLATION WITHOUT REPLACEMENT PANEL

1. Locate area for installation of the unit. The unit should be installed as close to wall as possible. Mark wall as shown in Figure 4 and cut a 9.5 cm (3.750") Diameter hole for vent installation. On mesa or yoder type side walls, it may be required to flatten area where vent is to be installed to ensure seal around vent assembly.
2. Place unit on floor (verify vent cap lines up with exhaust tube and combustion air opening in unit).
 - a. Drain lines must be connected to the system and condensation drains on the On Demand water heater and ran to the outside of the RV. Drain Lines should be as short as possible and must maintain a drop of 21 mm per meter (1/4" per foot) from unit. See Figure 5A.
3. Install vent assembly. See Figure 6.
 - a. Vent cap must be ordered separately. See TABLE 1 for vent sizes and part numbers. A minimum overlap of 3.2 cm (1.25") is required on exhaust.
 - b. Apply a bead of silicone around the vent cap as shown in Figure 6.
 - c. Install vent cap as shown in Figure 6 with screws. Ensure assembly is sealed to outside wall to prevent leaks.
4. Screw the front of the unit to the floor using the two brackets as shown in Figure 5A. If necessary, the brackets can be moved to the rear of the unit as shown in Figure 7B.
5. Make electrical, drain, water and gas connections following instructions contained in this manual or the manual supplied with the Suburban NAUTILUS (IW60A) On Demand Water Heater.

INSTALLATION USING REPLACEMENT PANEL

A replacement panel is used when replacing Suburban 22.7, 37.8, 45.4, or 60.6 Liter (6, 10, 12, 16 gallon) tank units and Atwood Style 22.7 and 37.8 Liter (6 and 10 gallon) tank units.

1. On mesa or yoder type sidewalls, flatten the wall area around the opening.
2. Apply a continuous line of suitable caulk on the RV wall around all four sides of the opening and around back side of replacement panel frame as shown in Figure 8. This caulk is required to create water tight seal of the frame to the RV wall.
3. Center and insert caulked replacement panel frame into opening. Push frame firmly against RV wall over caulking previously applied in step 2. Secure frame with the eight (8) supplied screws into RV wall as shown in Figure 8.
4. Locate the water heater cabinet approximately even with the inside RV wall. See Figure 7B. If securing the unit to the floor using the FRONT mounting brackets, proceed to STEP 5. To mount the water heater using the REAR mounting method, remove the two mounting brackets from the front of the unit and secure them to the threaded holes at the rear of the unit. Screw the rear of the unit to the floor using the two brackets. See Figure 7B.
5. Using the gasket supplied with the kit, apply the gasket beginning at the center bottom of the replacement panel frame. Adhere the adhesive side of the gasket to the replacement panel frame and install the gasket all the way around the frame. Ensure the ends of the gasket meet at the center bottom of the access panel frame.
6. Attach the replacement panel to the frame as shown in Figure 8 using the five (5) screws provided.
7. Vent cap must be ordered separately. See Table 1 for vent sizes and part numbers. There must be a minimum of 31.8mm (1.25") overlap of vent assembly tube over exhaust tube on the On Demand Water Heater and the replacement panel must compress the replacement panel gasket. See Figure 7A.
 - a. Apply a bead of silicone around the vent cap as shown in Figure 8.
 - b. Install vent cap as shown in Figure 8 with four (4) screws. Ensure assembly is sealed to outside wall to prevent leaks.
8. Screw the front of the unit to the floor using the two brackets as shown in Figure 5A.
9. Apply silicone caulk around the beveled edges of the replacement panel as shown in Figure 8. Do not caulk the bottom of the replacement panel.
10. Make electrical, drain, water and gas connections following instructions contained in this manual or the manual supplied with the Suburban NAUTILUS (IW60A) On Demand Water Heater.

REPLACEMENT PANEL PART NUMBERS

BRAND	CAPACITIES	PART NUMBER
SUBURBAN	22.7 Liter (6 Gallons)	6276APW (Polar White)
SUBURBAN	37.8, 45.4, or 60.6 Liter (10, 12, 16 Gallons)	6277APW (Polar White)
ATWOOD	22.7 Liter (6 Gallons)	521147 (Polar White)
ATWOOD	37.8 Liter (10 Gallons)	521150 (Polar White)

VENT CAP PART NUMBER	VENT CAP LENGTH	"X" MAX DIMENSION SEE FIGURE 7A
260616	0 - 2.5cm (0 - 1 inches)	2.97 cm (1.171 inches)
260617	2.5 - 5.0 cm (1 - 2 inches)	5.51 cm (2.171 inches)
260618	5.0 - 7.6 cm (2 - 3 inches)	8.05 cm (3.171 inches)
260638	7.6 - 15.2 cm (3 - 6 inches)	15.7 cm (6.171 inches)

TABLE 1

MAKING ELECTRICAL CONNECTIONS 12 VOLTS D.C. (SEE FIGURE 11)

- A. The electrical connections must be made in accordance with local codes and regulations.
- B. Make the 12 Volt D.C. electrical connections following the wiring diagram illustrated in Figure 11.

If the power supply is to be from a converter, we recommend that the converter system be wired in parallel with the battery. This will serve two purposes:

1. Provide a constant voltage supply
2. Filter any A.C. spikes or volt surges

We recommend insulated terminals be used for all electrical connections.

INSTALLATION OF ON DEMAND CONTROL CENTER (SEE FIGURE 13)

1. On Demand Control Center is wired as shown in wiring diagram. See Figure 11.
2. Locate the On Demand Control Center on a wall surface adjacent to the On Demand water heater.
3. Remove back cover from control center by depressing latch at bottom.
4. Remove center knockout from back cover. Drill hole for wiring from control center. See Figure 13.
5. Mount back cover to the wall.
6. Route wiring through back cover and hole into wall.
7. Connect the two white wires from the On Demand Control Center to the two white wires from the On Demand water heater. See Figure 11.

The On Demand Control Center displays the setpoint water temperature and also allows outlet water temperature to be adjusted from 35°C/95°F to 50°C/122°F.

ON DEMAND CONTROL CENTER	PART NUMBER
WHITE	161271
BLACK	161272

MAKING DRAIN CONNECTIONS (SEE FIGURE 5A)

- A. Drain connections are made at the front of the water heater. Refer to Figure 5A. Connect 16 mm (5/8") ID hose to system drain fitting provided on front of unit. Connect 13 mm (1/2") ID hose to condensation drain fitting provided on front of unit.
- B. Drain lines must run to the outside of the RV. Drain lines should be as short as possible and must maintain a minimum drop of 21 mm per meter (1/4" per foot). See Figure 5A.

MAKING WATER CONNECTIONS (SEE FIGURE 5A, 5B)

1. Water connections are made at the front of the water heater. Refer to Figure 5A.
2. **PIPE SIZES** - The pipe sizing for hot water supply systems should be carried out by persons competent to do so, choosing the most suitable pipe size and pipe routing to ensure adequate flow for each individual application. To achieve good flow performance, the cold water line to the water heater should be the same size or larger than the hot water line from the water heater. The minimum recommended cold and hot water supply pipe size is 13mm (1/2"). Refer to Figure 5B.

3. Connect the hot and cold water lines to the **1/2" BSPT** female pipe fittings provided on front of unit. These fittings are marked "HOT" and "COLD".
 - a. **IMPORTANT:** Use a pipe thread compound suitable for potable water or pipe thread tape on all connections to assure they will not leak.
 - b. For ease of removal, it is suggested that a pipe union be installed in each water line.
4. Fill system with water. Open both hot and cold water faucets to expel air from system. When system is filled and water flows from faucets, close both faucets and check all connections for leaks.

MAKING GAS CONNECTIONS

- A. Connect a 9.5 mm (3/8") gas supply line to the 9.5 mm (3/8") flare fitting at gas valve. When making the gas connection, hold the gas fitting on the valve with a wrench when tightening the flare nut. Failure to hold fitting securely could result in a gas leak due to fitting being damaged.
- B. Turn on gas and check all fittings and connections for leaks using a soap and water solution. Correct even the slightest leak immediately.

NOTE: When replacing your water heater with an NAUTILUS (IW60A) On Demand water heater, review your gas regulator to ensure it can maintain a proper gas flow during the operation of the On Demand water heater and other gas burning appliances.

NOTE: Regulator switch over pressure may be lower than main operating pressure.

Maximum Capacity of Pipe in MJ per Hour for Gas Pressures of 3 kPa or Less and a Pressure Drop of 0.25 kPa.

INTENDED USE: Tubing sizing between single or second-stage (low pressure) regulator and appliance.				
AS1432 TYPE B				
Nominal	15	20	25	32
Outside Diameter (mm)	12.7	19.1	25.4	31.8
Inside Diameter (mm)	11.9	18.1	24.2	30.6
Length (m)	Capacity in MJ per Hour			
2	159	525	1153	2212
6	88	290	637	1221
10	67	220	483	926
14	55	183	402	772
18	48	160	351	674
NZS 3501				
Nominal	10	15	20	25
Outside Diameter (mm)	11.4	14.7	21.1	27.4
Inside Diameter (mm)	9.5	12.7	19	25.4
Length (m)	Capacity in MJ per hour			
2	123	264	759	1025
6	68	146	419	897
10	52	110	318	680
14	43	92	265	567
18	38	80	231	495

OPERATING INSTRUCTIONS WITH ON DEMAND CONTROL CENTER (SEE FIGURE 12)

1. **STOP!** Read the safety information provided in the Operation Manual that came with your unit.
2. Turn off all electric power to the appliance.
3. Turn "OFF" gas supply.
4. Wait five minutes for gas to clear the area. If you smell gas then **STOP!** Follow instructions in item B of the SAFETY INFORMATION provided in the Operation Manual that came with your unit. If you do not smell gas, go to next step.
5. Turn "ON" gas supply.
6. Turn on electrical power to the appliance.
7. **PRESS THE "ON" button.** The On Demand Control Center is illustrated in Figure 12. Your On Demand Control Center is located somewhere inside the RV. There must be a hot water faucet **OPEN** to a minimum of 1.9 LPM (0.5 GPM) for the unit to operate. If the burner does not light, the system will automatically attempt two more tries for ignition before lock-out.

8. If lockout occurs, an ERROR CODE will be displayed on the On Demand Control Center and the unit must be re-cycled by turning the faucet OFF or by pressing the OFF button on the On Demand Control Center and then back ON. The first start-up of the heater may require several ignition cycles before all air is purged from the gas lines. This On Demand Water Heater is factory set at 49°C/120°F.

To change the water temperature settings:

1. Press the UP or DOWN arrows on the On Demand Control Center to increase or decrease the SET water temperature in single degree increments. The water temperature set range is 35°C/95°F to 50°C/122°F. See Figure 12.

SEQUENCE OF OPERATION

1. Turning on a hot water faucet activates the On Demand Water Heater.
2. The water heater senses the flow of water.
3. The water heater proves that the combustion air fan is working.
4. The combustion chamber is then purged of any remaining raw gas.
5. The burner will ignite and prove the flame.
 - a. The approximate time from turning on the faucet to ignition is 7 seconds. After the initial lighting sequence and the water heater is maintaining temperature, the ignition cycle is reduced to approximately 5 seconds.
 - b. Burners will stay ON until the water flow is shut off.
6. The flow of hot water at the SET point begins approximately 3 seconds after ignition but will not reach the faucet until the hot water lines leading to the faucet are cleared of any remaining water. This time is determined by the length of the hot water line.
7. When the hot water faucet is turned OFF, the water heater shuts down and will remain in a ready state until hot water is called for again.

NOTE: Blower motor will operate for approximately 20 seconds after the hot water faucet is turned OFF.

8. The On Demand Control Center can be left in the ON position and no further action is required by the user.
9. If the water heater fails to light for any reason, a second Trial For Ignition(TFI) will automatically begin. If the second Trial For Ignition(TFI) fails, the water heater will automatically begin a third Trial For Ignition(TFI). If the third Trial For Ignition(TFI) fails, the water heater will go into a lock out mode and will not try to light the burner again.

To reset:

- a. Turn faucet OFF, then back on.

NOTE: The NAUTILUS (IW60A) On Demand Water Heater has an energy mode circuit that will shut down operation if operating continuously for three (3) hours. To reset, follow the instruction in STEP 9A above.

NOTE: Air in the gas line after changing propane tanks is the main reason for not lighting the burner. A simple method to remove air from the gas line is to ignite a burner on the installed cooking appliance inside your RV.

OPERATING FAUCETS and SHOWER with the NAUTILUS (IW60A) ON DEMAND WATER HEATER

- A. All faucets must be operated the same as you would in your home.
- B. Cold water must be added to achieve the desired hot water temperature.
 1. If this is the first use of the unit for the season, turn water supply on and open each faucet and allow all air to be purged from the water lines.
 2. Turn ON power supply.
 3. Turn ON propane supply. Hot water faucet may have to be cycled several times to purge gas supply.
- C. The water heater only heats when there is a call for water (open hot water faucet).
- D. A minimum of 1.9 LPM (0.5 GPM) is required for water heater to operate.
- E. Faucet should be turned on and adjusted to desired temperature and flow before entering shower.
- F. Showerhead button should NOT be used. Using the showerhead button will create a drop in temperature by reducing or stopping the

flow of water through the water heater causing the water heater to shut down.

TO TURN OFF THE ON DEMAND WATER HEATER

1. On the On Demand Control Center, press the power button once.
2. Turn off electrical power to the appliance.
3. Turn off gas supply.
4. If vehicle is to be stored or heater is going to be turned off while subject to freezing temperature, drain water heater. (See "Draining and Storage Instructions.")

OPERATIONAL TROUBLESHOOTING

NOTE: There must be a demand of at least 1.9 LPM (0.5 GPM) for the burner to operate and allow water flow. This will continue until the water flow is turned OFF and the system goes dormant.

NO WATER FLOWS FROM FAUCET WHEN TURNED ON:

1. Be sure water supply is turned ON and there are no water restrictions.

BURNER TURNS ON, TEMPERATURE FLUCTUATES ERRATICALLY:

1. Clean all shower heads, faucet aerators or water strainers as required and remove any flow restrictions to assure the minimum 1.9 LPM (0.5 GPM)

ON DEMAND HEATER COMES ON AND RAPIDLY CYCLES ON AND OFF:

1. Water flow is too low. Increase flow at faucet.
2. Clean all shower heads, faucet aerators or water strainers as required and remove any flow restrictions to assure the minimum 1.9 LPM (0.5 GPM) of water flow.
3. Verify the water pump is functioning properly.
4. Bleed air out of plumbing lines by opening all water faucets.
5. If the On Demand Water Heater cycles as the pump cycles, an accumulator tank is needed in the water system. If accumulator tank is already installed, check for water inside the tank and drain tank until only air is present.
6. Water source pressure fluctuates too low causing loss of flow. Check the incoming water source for a minimum of 207 kPa (30 psi).

WATER TEMPERATURE IS TOO LOW WITH LOWER WATER FLOW:

1. Water flow is too low. Increase flow at faucet to assure the minimum 1.9 LPM (0.5 GPM) of water flow.

WATER TEMPERATURE IS TOO HIGH OR NO TEMPERATURE CONTROL:

1. Press the UP or DOWN arrows on the On Demand Control Center to increase the SET water temperature in single increments. Refer to OPERATING INSTRUCTIONS FOR ON DEMAND CONTROL CENTER and see Figure 12.

LOW TEMPERATURE RISE AND EXCESSIVE WATER FLOW REQUIRED TO TRIGGER THE ON DEMAND WATER HEATER:

NOTE: If you find that your water heater requires excessive flow to activate it (over 0.8gpm(3.0Lpm)), it is possible that you have COLD water bleeding into the HOT water side of your water system.

1. Verify that valves and faucets are closed when not in use. Check the shower head for an ON/OFF button/lever and ensure it is in the OFF position to prevent cold water from bleeding into the hot water system. This can keep the On Demand Water Heater from functioning correctly.
2. If your RV is equipped with a bypass valve at the water plumbing connection, make sure it is in the OFF position. An open valve can allow water to bypass water heater causing a failure to ignite.

NO IGNITION:

If the burner will not come on, the following items should also be checked before calling a service technician:

- A. On Demand Control Center is turned off.
- B. 12 VDC power is OFF
- C. Check gas supply is available to the water heater.
- D. Water turned on and faucet open.

- E. Check manual reset on ECO switch. Refer to DETAIL "A" in Figure 9.

If burner fails to light, call a local RV service agency.

MAINTENANCE

- A. Periodically inspect unit for soot. If soot is present anywhere on water heater, immediately shut unit down. Soot is a sign of incomplete combustion and must be corrected before operating water heater. Areas to check would include:
 1. Check for an obstruction in vent cap.
 2. Check vent to see that no foreign material has accumulated to prevent flow of combustion and ventilating air.
 3. Check to be sure there is no flame present at burner orifice or burner whenever main gas valve is closed. This can be checked by turning the unit off using the ON DEMAND control center.
- B. Periodically check wiring and wire connections to be sure wiring is not damaged/frayed and that all terminals and connections are tight and in compliance with codes (See "Making Electrical Connections").

DRAINING AND STORAGE INSTRUCTIONS

If RV is to be stored during winter months, the water heater system must be drained to prevent damage from freezing.

1. Turn off electrical power to water heater either using the On Demand Control Center or by removing the fuse.
2. Shut off gas supply to water heater.
3. Turn off pressure pump on water system.
4. Open both hot and cold water faucets.
5. Remove Service Panel to access system drain valve.
6. Turn drain valve knob clockwise to drain.
7. Follow RV manufacturer's instructions for draining entire water system.

NOTE: System will have to be refilled with water and all air removed from lines before unit will re-light.

NOTE: All water must be drained to the outside of the RV - Drain lines must be connected to the system and condensation drains on the water heater and ran to the outside of the RV. Drain lines should be as short as possible and must maintain a drop of 21 mm per meter (1/4" per foot) from unit. See Figure 10.

WINTERIZING

1. Follow RV manufacturer's instructions for draining entire water system.
2. Once drained, RV NON-TOXIC antifreeze can be added if recommended by your coach manufacturer.

FREEZE PROTECTION

The NAUTILUS (IW60A) On Demand water heater has built-in FREEZE PROTECTION and will intermittently cycle the burner when the water temperature has fallen below 4.4°C(40°F). This intermittent cycling will continue until the water temperature has risen above 10.0°C(50°F). To provide this freeze protection, gas and electrical must be turned on.

If the On Demand Water Heater is dripping water into the drain line, in cold weather, when the water supply temperature is below 3.3°C(38°F) and does not stop when the water temperature rises above 3.3°C(38°F), call your local service center. The valve may be disabled by turning the needle valve located on the front of the On Demand Water Heater 6 and 1/2 turns clockwise. Closing the valve will disable the mechanical freeze protection feature. The water system must be drained when not in use to avoid damage caused by ice expanding in water lines if valve is closed.

DESCALING INFORMATION

Each year, drain the water from the system and flush the heat exchanger with an approved descaling solution.

PRESSURE RELIEF VALVE

The temperature and pressure relief valve is designed to open if the temperature of the water within the heater reaches 99°C(210°F), or if the water pressure in the heater reaches 1 kPa (145psi).

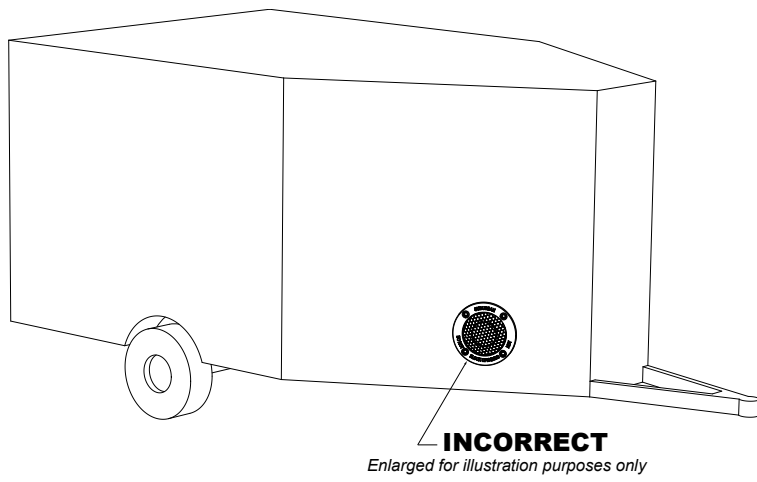

Figure 1

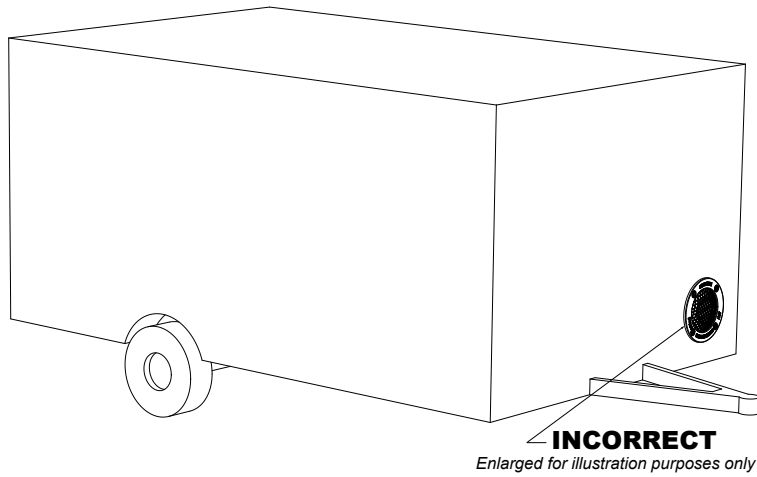

Figure 2

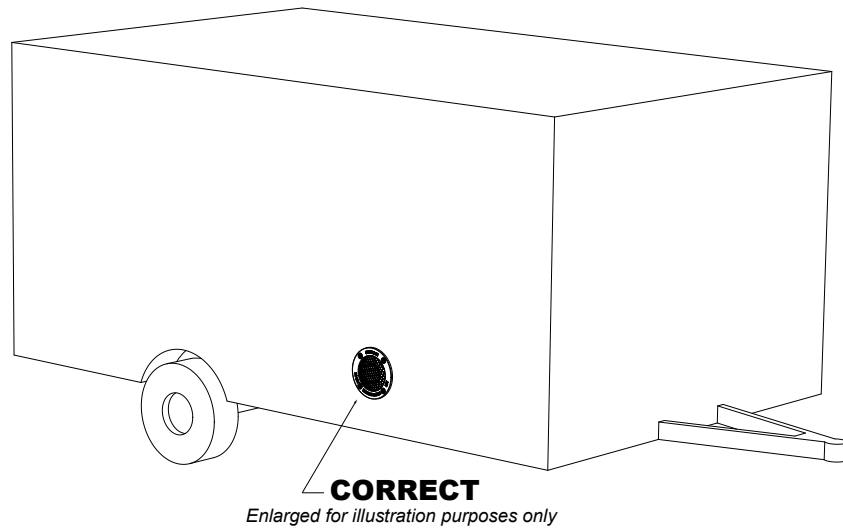

Figure 3

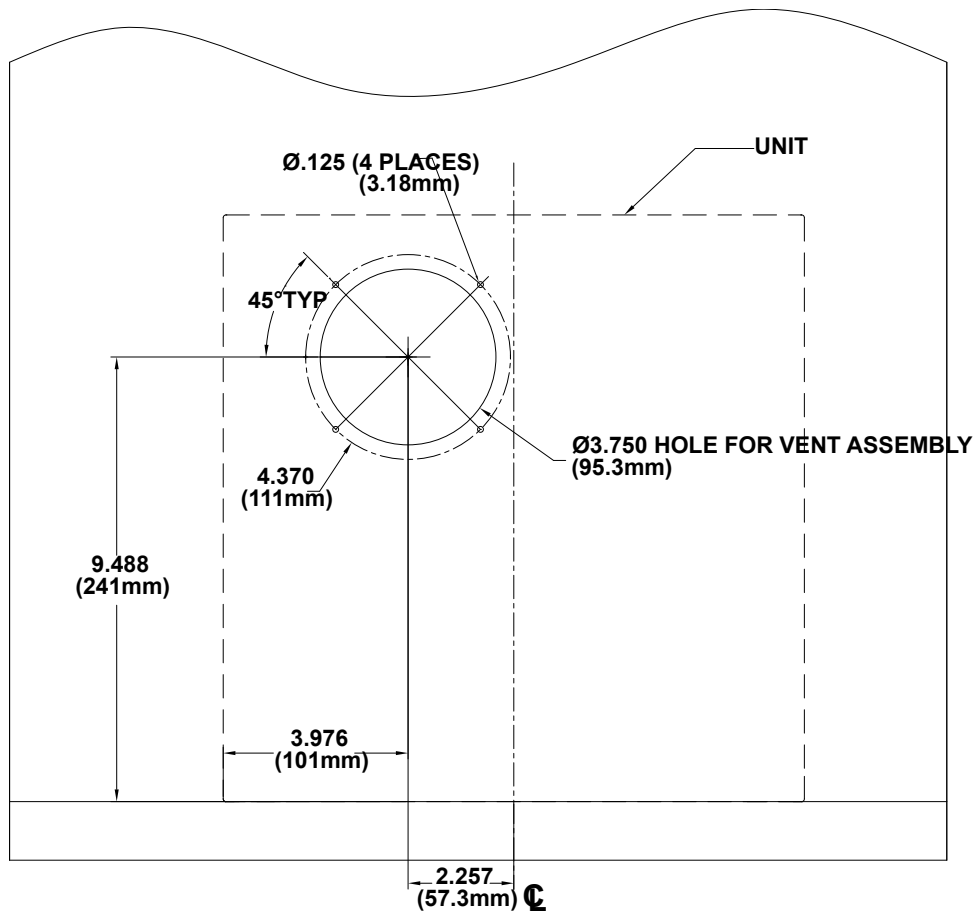

Figure 4

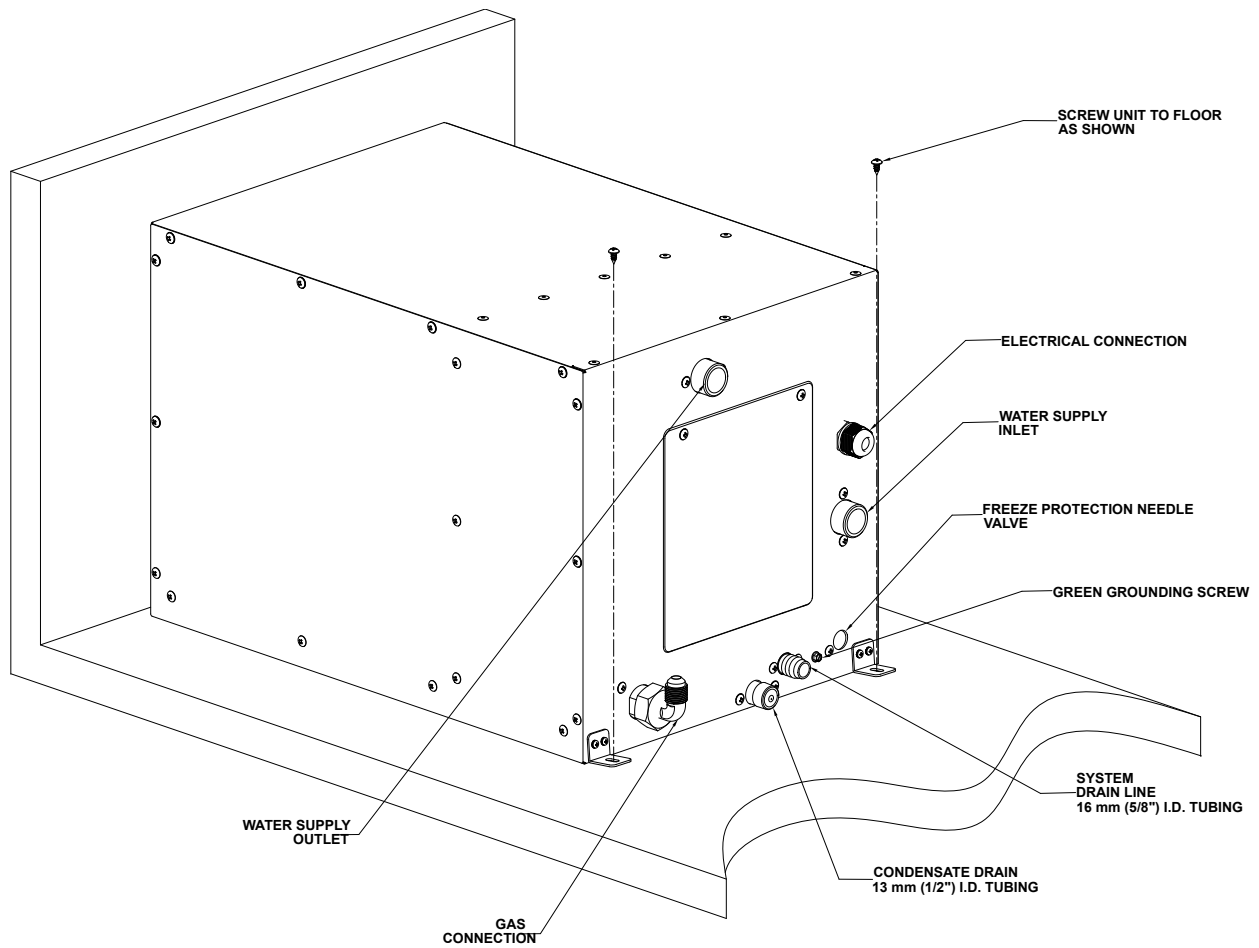
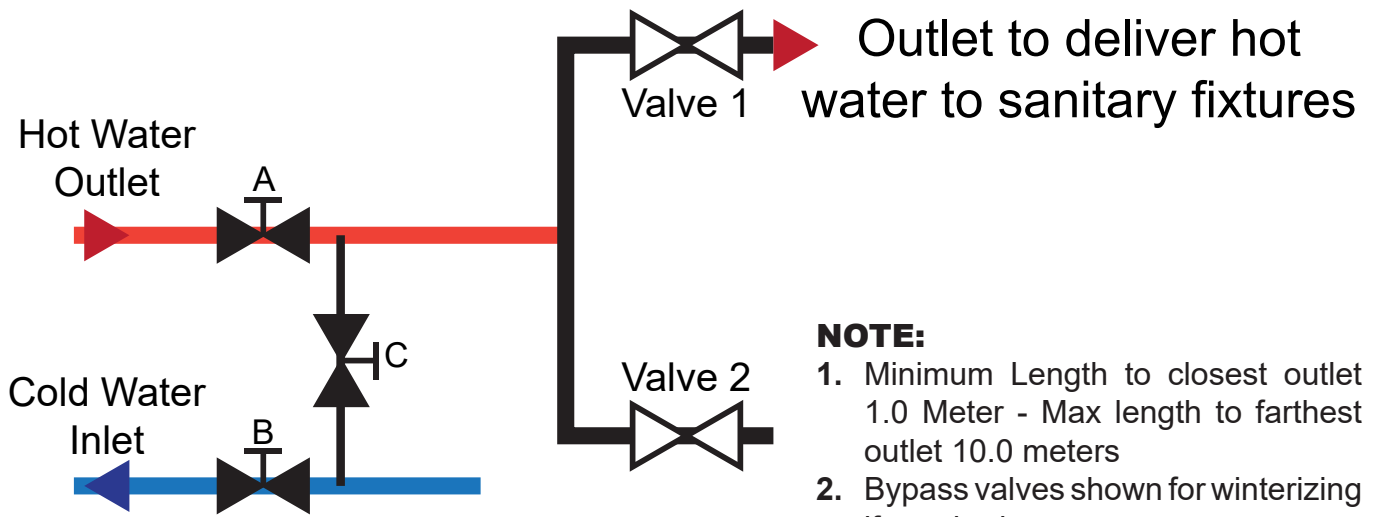

Figure 5A



NOTE:

1. Minimum Length to closest outlet 1.0 Meter - Max length to farthest outlet 10.0 meters
2. Bypass valves shown for winterizing if required.

Figure 5B

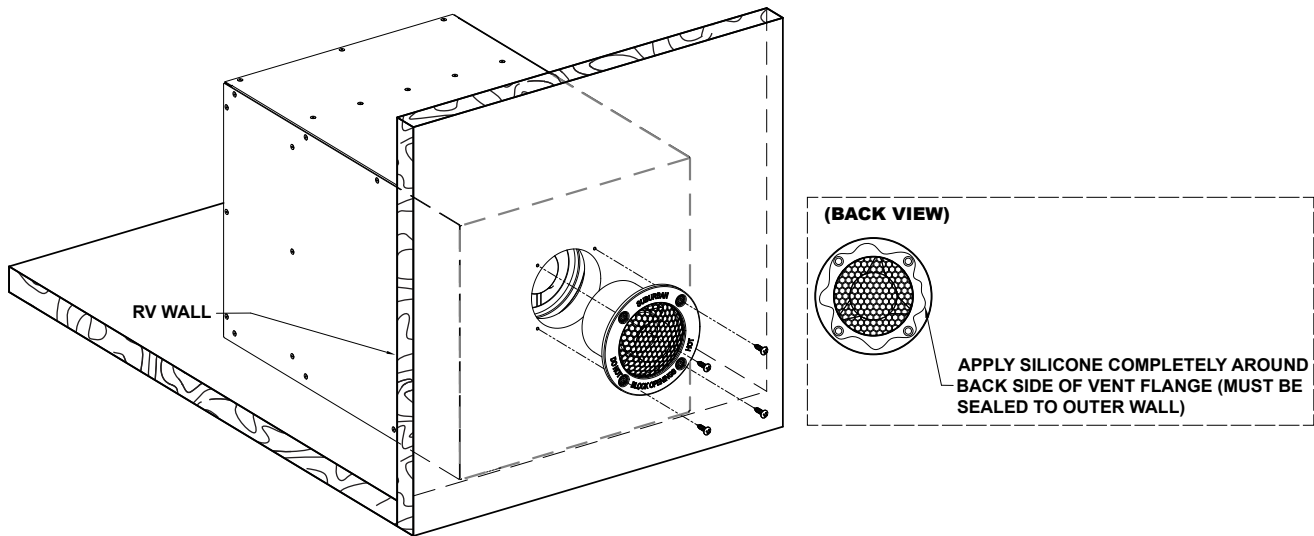

Figure 6

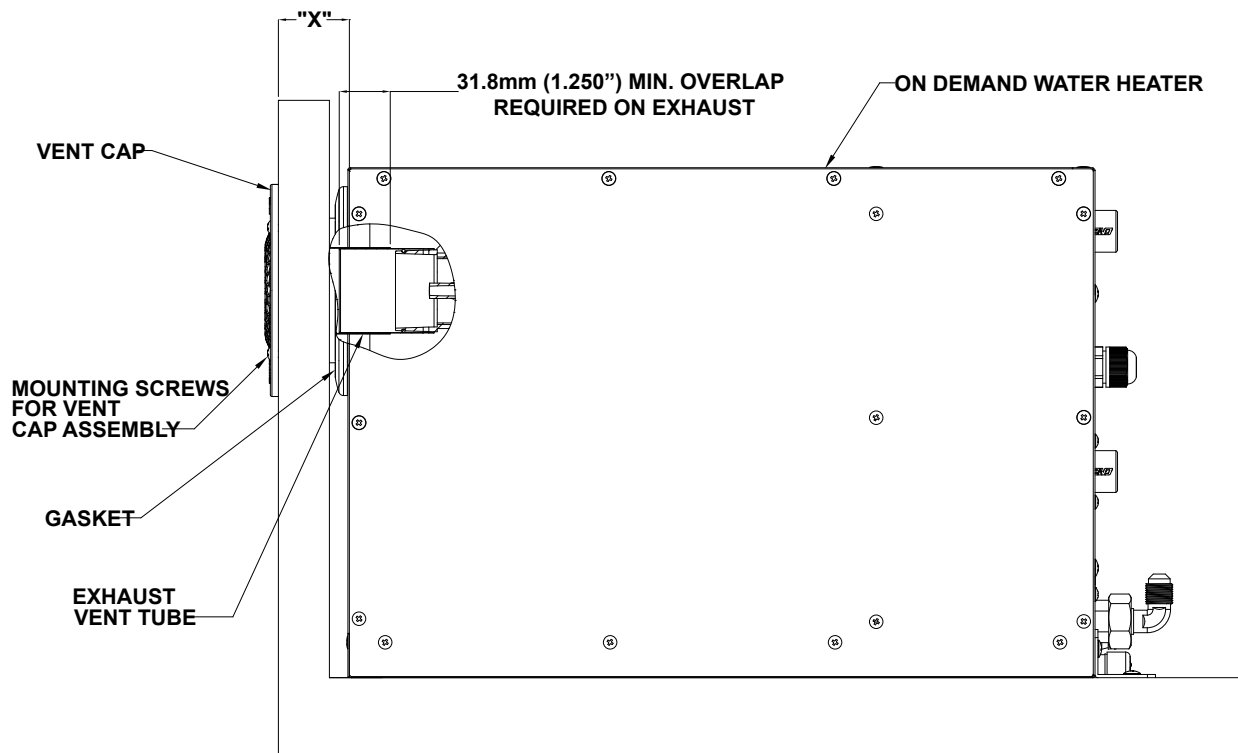
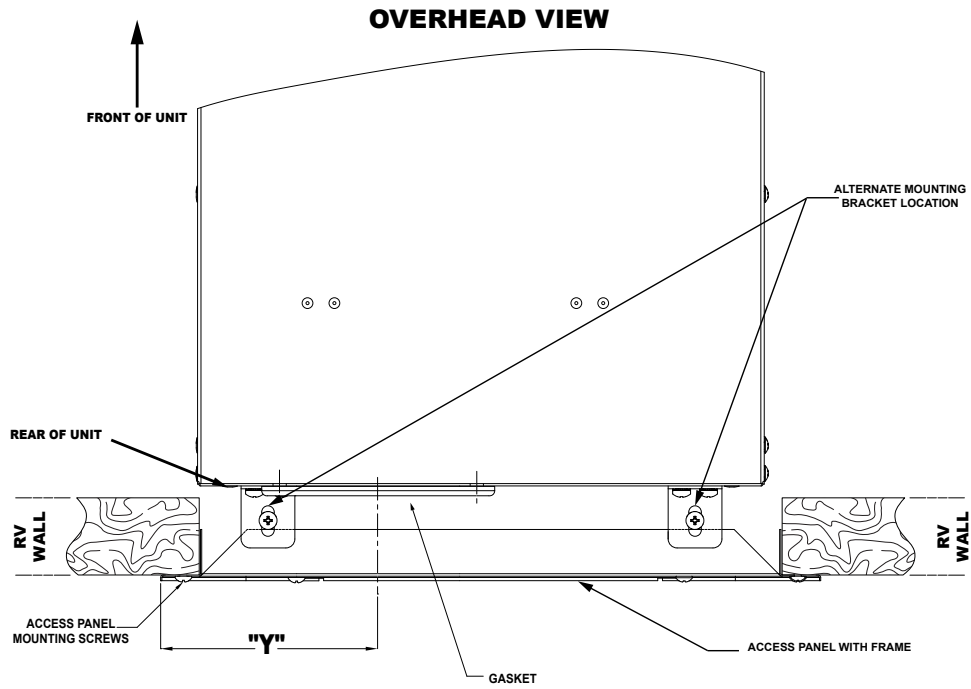

Figure 7A



SUBURBAN REPLACEMENT PANEL	"Y" DIMENSION
22.7 Liter (6 GALLON)	124.3mm(4.895")
37.8 Liter (10 GALLON)	168.5mm(6.634")

Figure 7B

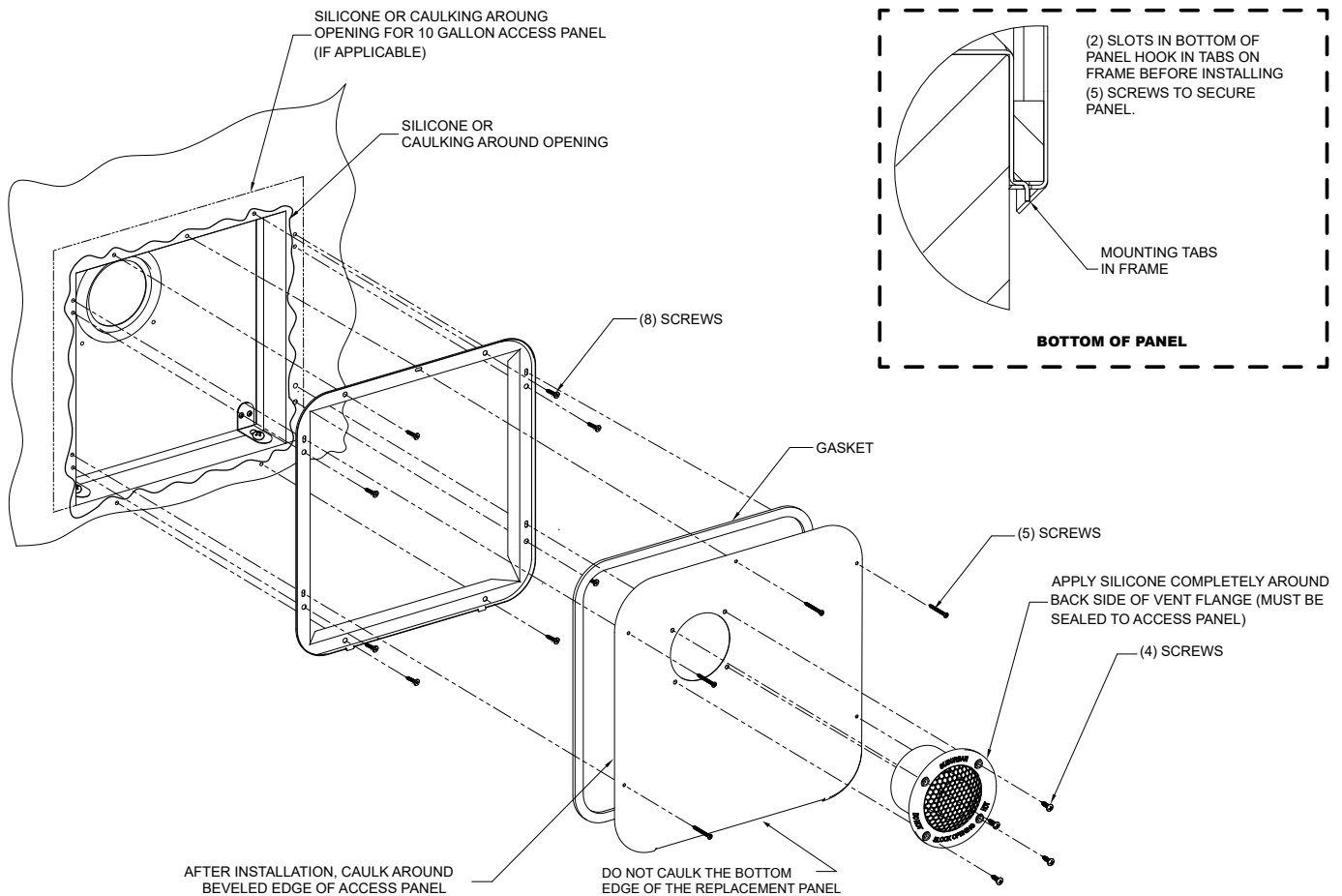

Figure 8

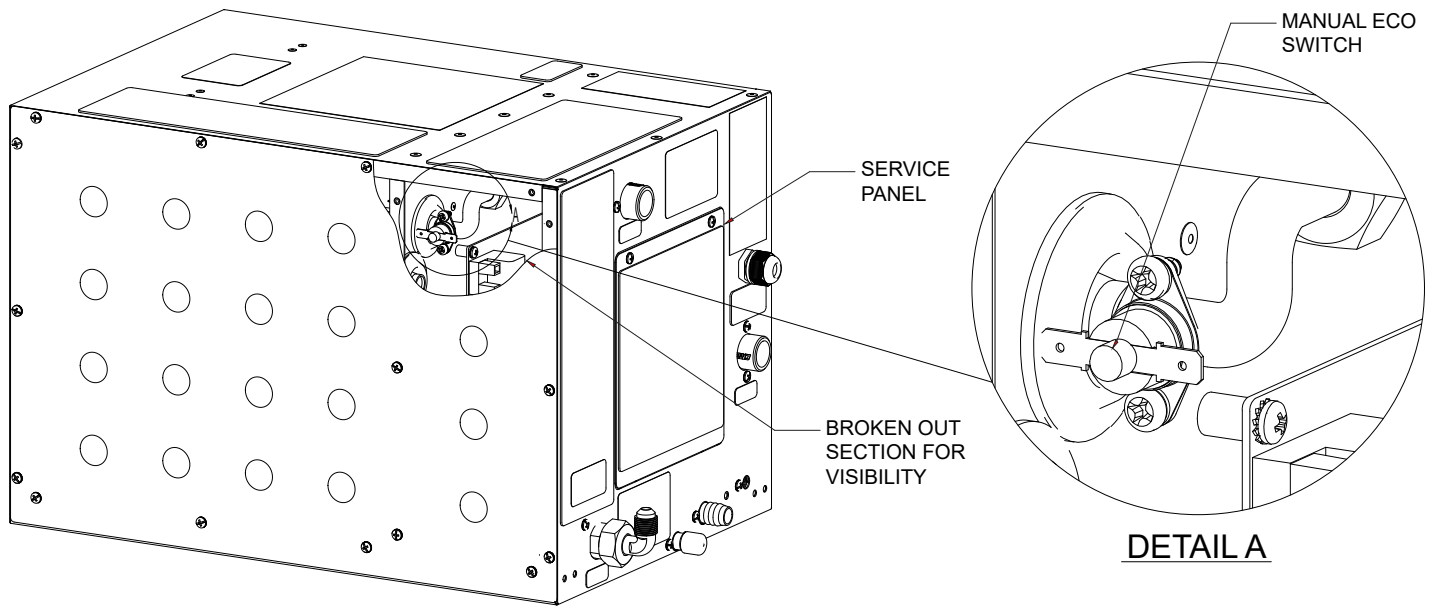

Figure 9

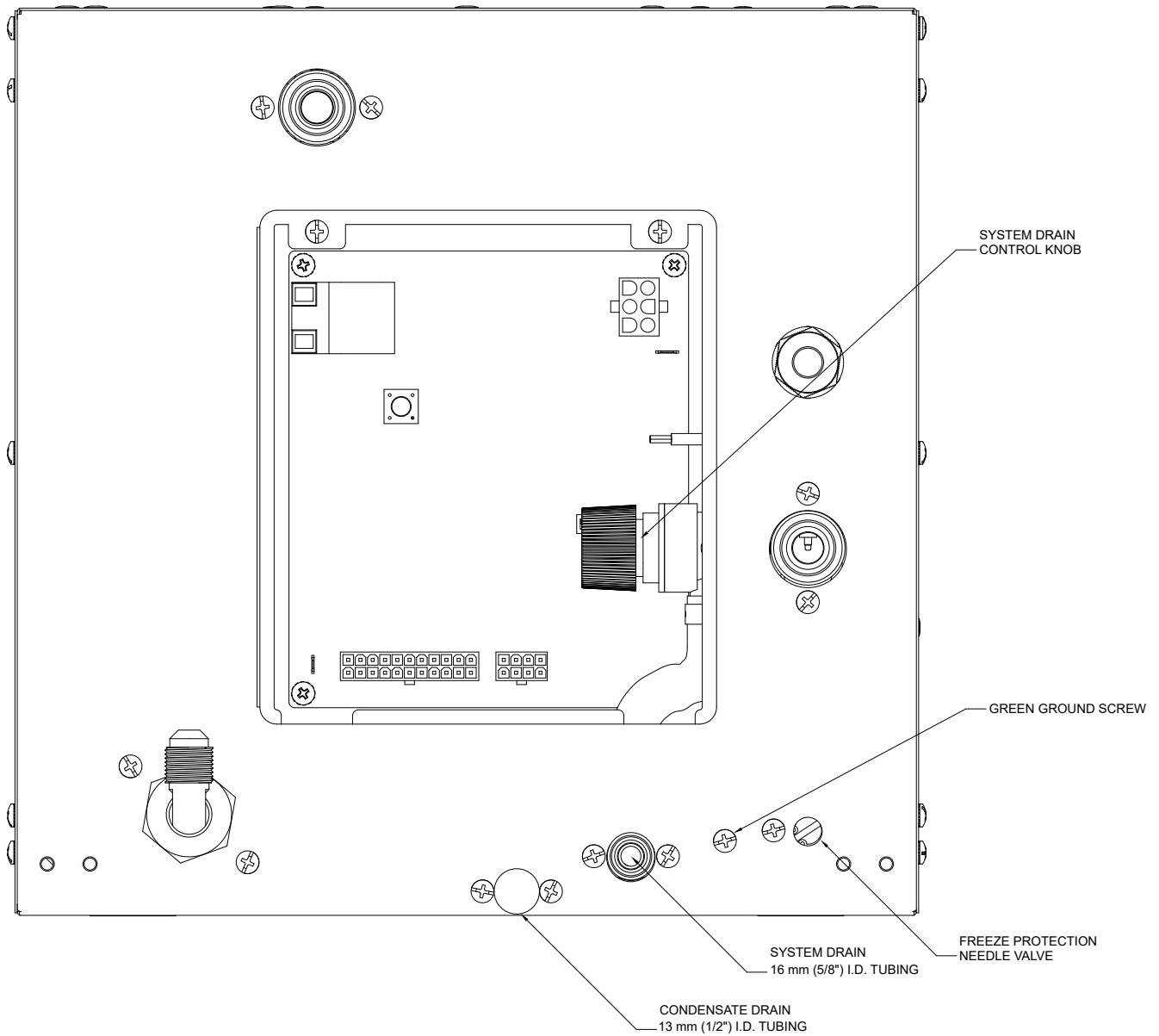

Figure 10

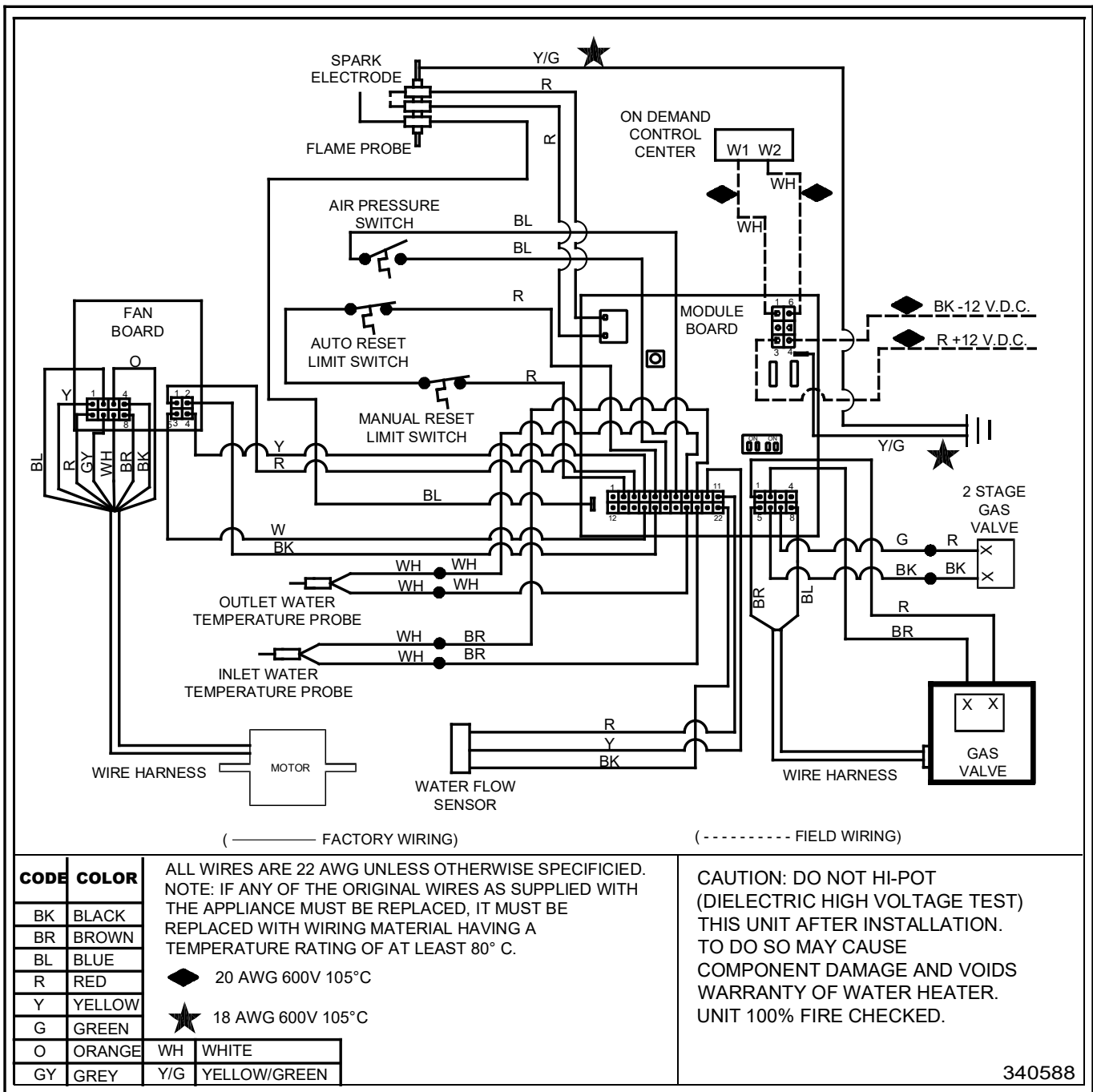
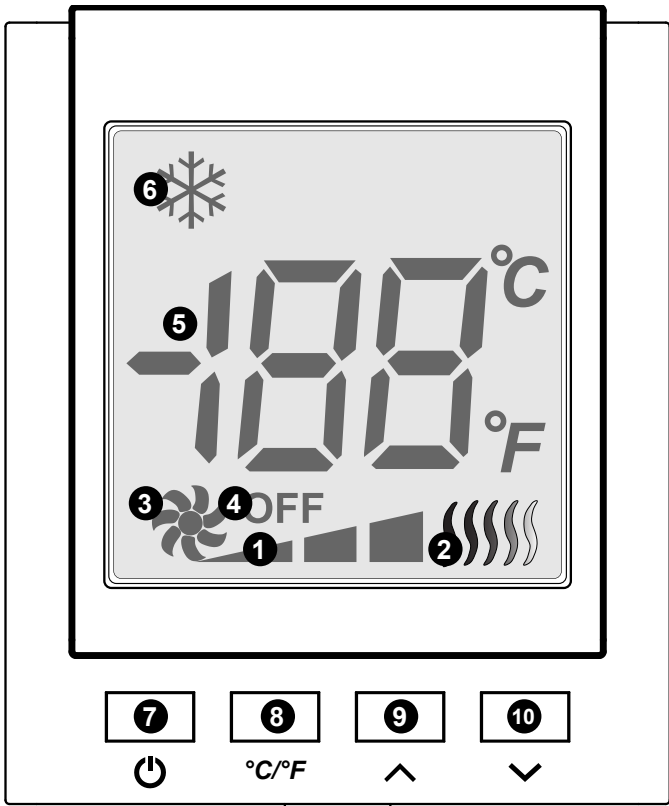

Figure 11

ON DEMAND CONTROL CENTER



DISPLAY DESCRIPTION			
1		BURNERS	2 BURNERS 5 BURNERS
2		FLAME	This icon is displayed when FLAME is established.
3		BLOWER	This icon is displayed when the BLOWER is running
4	OFF	STATUS INDICATOR	This icon is displayed when the Water Heater is in standby mode, ready to be used.
5		SETTING TEMP INDICATOR; OUTLET WATER TEMP INDICATOR	A. When setting the water temperature, the temperature display will flash. After SET Temperature is reached, the display stops flashing after a few seconds. B. When the demand for hot water has been terminated, the display will return to the SET Temperature. C. When the water heater is turned off, the letters "OF" will be display.
6		FREEZE PROTECTION	This icon is displayed when the FREEZE PROTECTION MECHANISM is engaged.
BUTTON DESCRIPTION			
7		ON/OFF	Power Button. Switch from turning unit ON or turning unit OFF.
8		SWITCH	Hold for 5 seconds to switch between degrees (°) Celsius or degrees (°) Fahrenheit
9		UP	INCREASE SET Temperature by 1 degree increments. Setting range is 35°C/95°F to 50°C/122°F
10		DOWN	DECREASE SET Temperature by 1 degree increments. Setting range is 35°C/95°F to 50°C/122°F

Figure 12

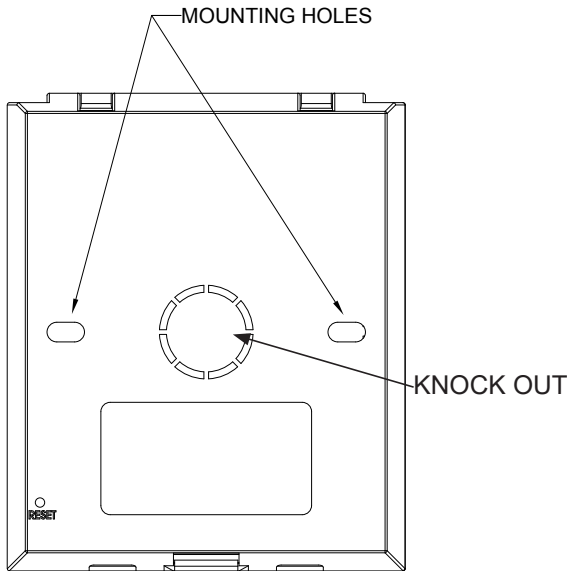
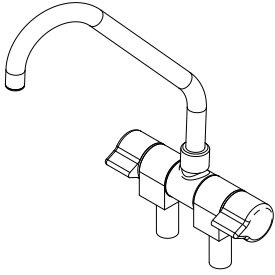
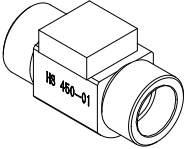
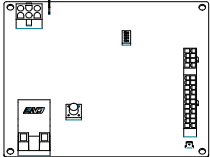
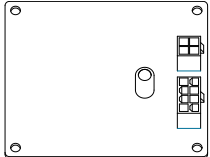
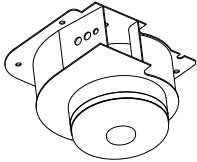
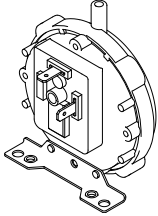

Figure 13

SEQUENCE OF OPERATION

COMPONENT		ACTION
	<p>FAUCET</p>	<p>Turning on a hot water faucet activates the DEMAND Water Heater.</p>
	<p>FLOW SENSOR</p>	<p>The water heater flow sensor senses the flow of water.</p>
	<p>MODULE BOARD IW60A</p>	<p>The water heater module board receives voltage signal from sensor and provides power to the Fan control module board. (time line 2-3 seconds).</p>
	<p>MODULE BOARD IW60A FAN BLOWER</p>	
	<p>BLOWER ASSEMBLY</p>	<p>The combustion air blower motor starts and completes the circuit to the Pressure switch. (2-3 seconds).</p>
	<p>PRESSURE SWITCH</p>	

SEQUENCE OF OPERATION

COMPONENT

ACTION

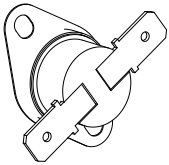
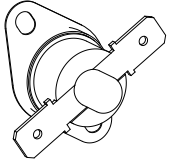
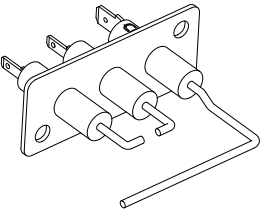
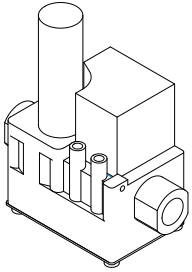
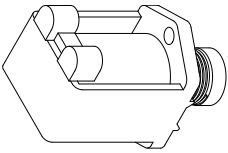
	<p>SENSOR OVERHEAT</p>	<p>Voltage is completed through the Limit and over-heat sensor switches.</p>
	<p>LIMIT SWITCH</p>	
	<p>ELECTRODE / FLAME PROBE ASSEMBLY</p>	<p>Module board receives voltage and ignition circuit begins (approximately seven (7) seconds from faucet being turned ON). Spark and gas valve are energized (ignition cycle approximately seven (7) seconds).</p>
	<p>GAS VALVE</p>	<p>Flame sense is confirmed during trial for ignition (TFI) time frame</p>
	<p>REGULATOR TWO STAGE</p>	<p>Burners will remain ON until the water flow is turned OFF. NOTE: Depending on demand the Proportional valve will energize two (2) orifices or five (5) during cycle.</p> <p>Blower motor will operate approximately 20 seconds after the hot water faucet is turned OFF.</p>

NOTE: If ignition fails on first TFI there is prepurge time of three (3) seconds and ignition begins with a seven (7) second TFI if flame is not detected in second TFI it goes into a third TFI if flame is not detected the module board goes into LOCKOUT and requires reset of Power or turn faucet OFF then back ON to start cycle.

If the ON DEMAND CONTROL CENTER is connected an E1 code will be displayed. Reset switch or turn faucet OFF and back ON to start cycle.

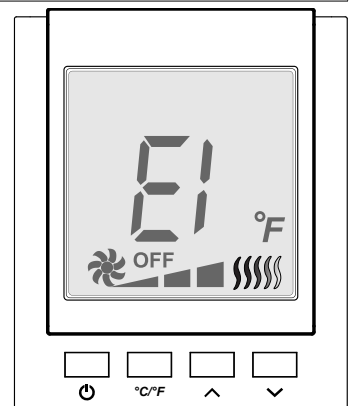

ERROR CODES

FAULT INDICATION	CODE MEANING	FAULT CAUSE	FAULT CONDITION
E1	Ignition fault	Flame signals undetectable after igniting twice	LOCKED
E2	Accidental stall fault	Without flame during combustion	LOCKED
E3	“False fire fault” “Residential fire fault”	Flame signals detected before start, Stop burning 4S, flame signal is detected	LOCKED
E4	Water overheating	Water output NTC>90°C °F	LOCKED
E5	Thermal switch fault	Overheat switch off	LOCKED
E6	Air pressure switch fault*	Air pressure switch or fan abnormal	LOCKED
E7	Water entry NTC fault	Water entry NTC open/short circuit	AUTOMATIC RECOVERY
E8	Module Board Fault	Module Board Failure	LOCKED
E9	Water NTC fault	Water input/output NCT open/short circuit	AUTOMATIC RECOVERY
EC	Communication failures	Line controller communication failure	AUTOMATIC RECOVERY

TROUBLESHOOTING GUIDE

NAUTILUS
ON DEMAND RV WATER HEATER



MODEL:
IW60A
FOR RECREATIONAL
VEHICLE USE ONLY

To use this guide, look up the symptom in the FAULT column. Test each possible cause in the order listed using the steps provided to determine what corrective action to take.

If an ERROR code is present, look up the ERROR CODE using the column provided. Test each possible cause in the order listed using the steps provided to determine what corrective action to take.

NAUTILUS (IW60A) ON DEMAND WATER HEATER TROUBLESHOOTING GUIDE

FAULT	STEP	POSSIBLE CAUSE	TEST	CORRECTIVE ACTION	IN COACH REPAIR?	ERROR CODE
WATER HEATER WILL NOT START	1		Verify fuse is properly seated in both terminals	Remove fuse and insert properly into terminal	YES	N/A
		2	Blown fuse (either)	Check polarity of supply voltage - Black (-12 VDC), Red (+12 VDC)	Correct polarity if incorrect, replace fuse	YES
	3		Verify white wires are not connected to supply voltage.	Disconnect white wires from anything other than the ODCC. Verify they cannot make contact with any possible ground or supply voltage.	YES	N/A
	4	Supply voltage	Check incoming voltage - should be 10.5-14 VDC	Troubleshoot RV power supply	YES	N/A
	5	Module Board	Unit keeps blowing fuses during fuse replacement	Verify polarity is correct and blue/orange wires are not connected to supply voltage or ground, verify white wires are not connected to supply voltage or ground. If all this is still correct, replace Module Board.	YES	N/A
	6	Module Board	Unit displays E8 error code when given demand	Replace Module Board	YES	E8
	8	Water flow sensor	Turn one faucet to a very slow trickle of water, then measure voltage between pin #10 (yellow) and pin #22 (black). The voltage should be fluctuating, if not, try altering the water flow slightly and rechecking voltage.	If voltage remains constant regardless of the flow rate, replace flow sensor	YES	N/A
	9	Inlet water temperature probe (NTC)	Inspect seating of NTC probe	Correct seating of NTC probe	YES	E7
	10		Verify switch continuity. Resistance should be between 100Ω and 200kΩ	Replace NTC probe	YES	
	10		Check terminals in all wiring harnesses accessible from control panel to verify each terminal is fully seated in harness and no debris is blocking connection between terminals	Reset terminals in harness if loose, clean terminals if debris is found	YES	E6
	11	Blower not operating	Check voltage between pin #3 (red) and pin #16 (black) on input plug on control module board plug - should be 10.5-13.5 VDC	If all voltage parameters are correct, replace Blower Assembly 391127. If unit fails any of these parameters, replace Module Board 233232	YES	E6
			Check voltage between pin #1 (red) and pin #2 (black) on input plug on fan control board input block - should be 10.5-13.5 VDC			
			Check voltage between pin #4 (yellow) and pin #4 (black) on input plug on fan control board input block - should be 3.2 VDC			
			Check voltage between pin #4 (white) and pin #4 (black) on input plug on fan control board input block - should be 5.5 - 8.5 VDC			
			Check voltage between pin #5 (red) and pin #4 (black) on input plug on fan control board output block - should be approximately 5 VDC			
			Check voltage between pin #6 (gray) and pin #7 (white) on input plug on fan control board output block - should be approximately 2.5 VDC			
			Check voltage between pin #8 (brown) and pin #4 (black) on input plug on fan control board output block - should be approximately 2.5 VDC			

NAUTILUS (IW60A) ON DEMAND WATER HEATER TROUBLESHOOTING GUIDE

FAULT	STEP	POSSIBLE CAUSE	TEST	CORRECTIVE ACTION	IN COACH REPAIR?	ERROR CODE
FAN COMES ON, NO SPARK OCCURS, FAN SHUTS DOWN AFTER A FEW SECONDS	1	Pressure Switch Adapter	Debris/blockage inside pressure tap port located inside exhaust port	Remove blockage from unit	YES	E6
	2	Pressure switch hose	Ensure hose connected on both ends, not damaged	Replace pressure switch hose	NO	E6
	3	Pressure switch won't close	Remove wire harness, and check continuity across pressure switch, pin #6 (blue) and pin #7 (blue)	Replace pressure switch	NO	E6
	4	Blower Assembly	Very low RPM (less than 200) is observed, can be tested by placing a small piece of paper approx. 10.2 cm (4") from exhaust vent, if paper does not move, or moves very little, replace motor	Replace Blower Assembly	NO	E6
	5	No spark	Check spark electrode gap. Should be 3 mm (1/8") gap. Also search for cracks on electrode	Replace electrode	NO	E1
FAN COMES ON, SPARK OCCURS, UNIT IGNITES BUT GOES OUT, AND THEN REPEATS	1	Gas Valve	Check brown and red wires going to valve from board. Verify no debris is impeding terminal connection and verify terminals are full seated and secured to spade on valve. Verify terminals on board are fully seated inside harness	Correct terminal seating and clean terminal if needed	YES	N/A
	1	RV Gas Supply	Verify unit has sufficient LP supply (2.7 - 3.5 kPa (11-14" W.C.)	Troubleshoot RV fuel system.	YES	E1
	2	Gas Valve	Check voltage at pin #1 (red) and pin #2 (brown) of the gas valve plug on the control module board 233232. Should modulate between 2 and 7 VDC considering demand, if 0 VDC is observed, then replace module board 233232. Verify no debris is in terminals blocking connection and that all terminals are fully seated inside the wiring harness. If proper voltage is found, replace Gas Valve 161248	Replace Gas Valve 161248 or Module Board 233232	Gas Valve - No Module Board - Yes	E1
FAN COMES ON, SPARK OCCURS, UNIT SHUTS DOWN AFTER A FEW SECONDS			Verify wire plugged in and not damaged	Inspect Terminal and verify it is properly seated	NO	N/A
	3	Flame sense	Verify flame impingement of electrode via viewing window	Clean with nonabrasive pad, make minor position adjustments to cross two flame paths in a perpendicular fashion. If sensor can't be adjusted to proper position, may have to replace flame sense probe	NO	
			Use multimeter on μ A setting, depending on flow, it should read between 20-30 μ A while unit is in operation	Replace flame sense probe	NO	
FAN IS IN CONTINUOUS OPERATION REGARDLESS OF DEMAND	1	Module Board	Fan stays on	Replace Module Board	YES	E6
	1	On demand control center	Check set point	Adjust set point	YES	N/A
WATER TOO HOT	2	Outlet water temperature probe (NTC)	Inspect seating of NTC probe	Correct seating of NTC probe	NO	E9
			Verify switch continuity. Resistance should be between 100 Ω and 200k Ω	Replace NTC probe		
	3	Limit switch	Check continuity across pin #2 (red) and #5 (red). If not continuous, trace wiring to verify all connections are secure, and measure continuity across each individual limit switch. If either one does not have continuity, replace it	Replace limit switch	NO	E5

NAUTILUS (IW60A) ON DEMAND WATER HEATER TROUBLESHOOTING GUIDE

FAULT	STEP	POSSIBLE CAUSE	TEST	CORRECTIVE ACTION	IN COACH REPAIR?	ERROR CODE
WATER TOO COLD	1	Water flow	Verify water flow rate (gallons per minute) at faucet using bucket and stopwatch. Must be greater than 1.9 LPM (0.5 GPM) to function. Very high flow rates or very cold inlet water can also cause cold outlet water.	-	YES	N/A
	2	On demand control center	Check set point	Adjust set point	YES	N/A
	3	Gas supply	Verify gas supply is turned on, with a pressure of 2.7 - 3.5 kPa (11 - 14 " WC)	Troubleshoot RV gas supply	YES	E1, E2
	4	Modulating gas valve	Check voltage at pin #1 (red) and pin #2 (brown) of the gas valve plug on the control module board. Should modulate between 2 and 7 VDC considering demand	Replace gas valve	NO	N/A
	5	Secondary gas valve	Open two devices (ex: faucet + shower) to full hot, check for number of flames in viewing port. Should be more than 2 flames present. If only 2 are present, check voltage at pin #6 (green) and pin #7 (black) of the gas valve plug on the control module board. If voltage is present, replace valve, if no voltage is present, replace control module board	Replace gas valve or Replace module board	NO	N/A
	6	Flame sense	Verify wire plugged in and not damaged Verify flame impingement of electrode	Replace flame sensor	NO	N/A
	7	Clogged gas orifice	Use multimeter on μ A setting, depending on flow, it should read between 20-30 μ A while unit is in operation. Check gas orifice for clogs	Replace gas orifice of clogs	NO	N/A
WATER TEMPERATURE REPEATS GOING FROM HOT TO COLD	1	Module Board	Check voltage at pin #1 (red) and pin #2 (brown) of the gas valve plug on the control module board. Voltage should not exceed 8.5 VDC	Replace Module Board	YES	N/A
	2	Gas Valve	Gas Valve is fully engaged not modulating down	Replace Gas Valve	NO	N/A
UNIT OPERATES NORMALLY BUT ODCC WILL ONLY DISPLAY "OF"	1	Module Board	Module board is not properly communicating with ODCC	Replace Module Board	YES	N/A
	1	Freeze protection valve	With water in off position, locate screw underneath water inlet on outside of unit, turn screw CCW until fully seated. Turn water on at sink, if water still flows out of drain, make sure manual drain 172022 is in off position. If water continues to flow out drain 172020, gradually back screw on rear of unit CW and if water starts to flow from drain 172020, replace Freeze Valve 233307	Replace freeze protection valve	YES	N/A
WATER INSIDE CABINET	1	Leaking water line	Pinpoint leak location	Tighten components if leak occurs at threaded connection. Replace unit if not.	YES	N/A
	1	Vent blocked	Check for blockage in vent	Remove blockage	YES	E6
COMBUSTION/ SOOT PRESENT ON VENT CAP	2	Debris inside combustion chamber	Verify all drains are opened, not clogged. Remove side panel of unit and verify it is clean of any foreign contaminants.	Clean unit and drain lines	NO	N/A
	3	RV Regulator/Supply Hose	Verify regulator has sufficient output and supply hose has sufficient inside diameter with no kinks or obstructions	Replace regulator or supply hose	YES	N/A
LOW GAS PRESSURE	1	RV regulator	Check gas pressure	Replace RV regulator	YES	N/A
EXCESSIVE SOOT IN EXHAUST	1	Erratic burner	Check sight glass: all or most of flame should be blue. If flame is mostly yellow, remove unit and clean the area around combustion chamber	Clean area surrounding combustion chamber	-	N/A
	1	Gas valve not sealing properly	Check voltage at pin #1 (red) and pin #2 (brown) of the gas valve plug on the control module board while unit is in shutdown mode.	If voltage is 0 VDC - Replace gas valve If voltage is between 2-7 VDC - Replace control module board	NO YES	E3

REPLACEMENT PANELS



22.7 L (6 gal.) Suburban Replacement Panel

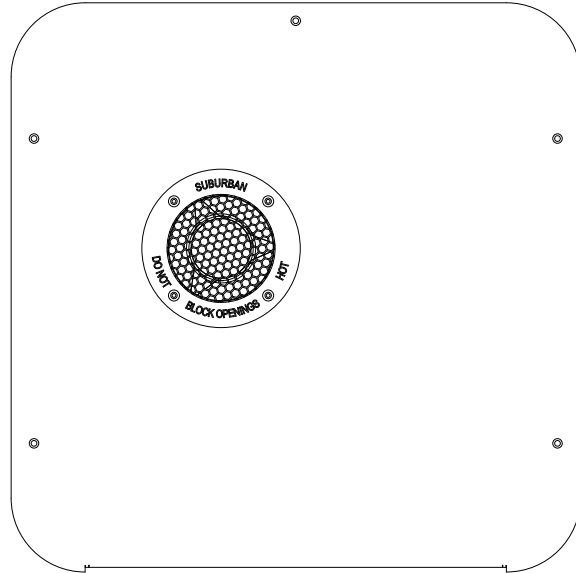

**37.8, 45.4, 60.6 L
(10, 12 or 16 gal.) Suburban Replacement Panel**

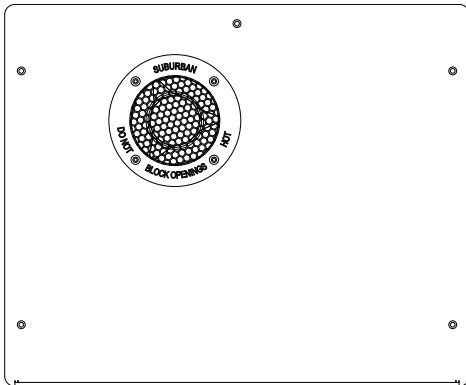

22.7 L (6 gal.) Atwood Style Replacement Panel

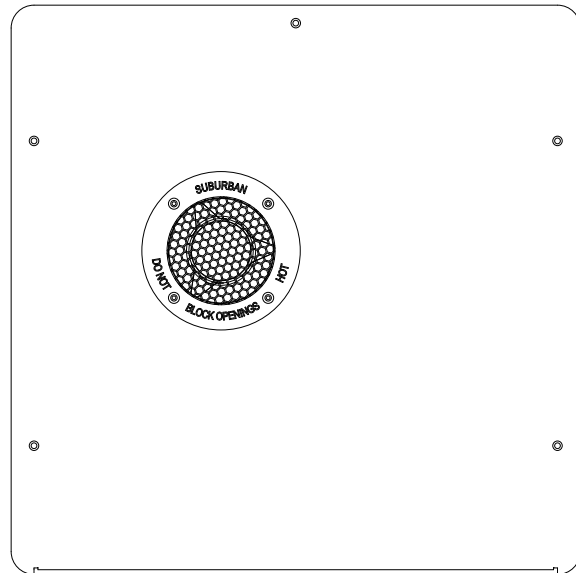

37.8L (10 gal.) Atwood Style Replacement Panel

VENT CAPS

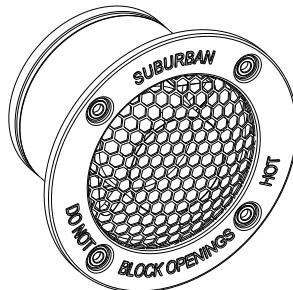

AVAILABLE IN 2.5 cm (1"), 5 cm (2"),
7.6 cm (3"), OR 15.2 cm (6") lengths

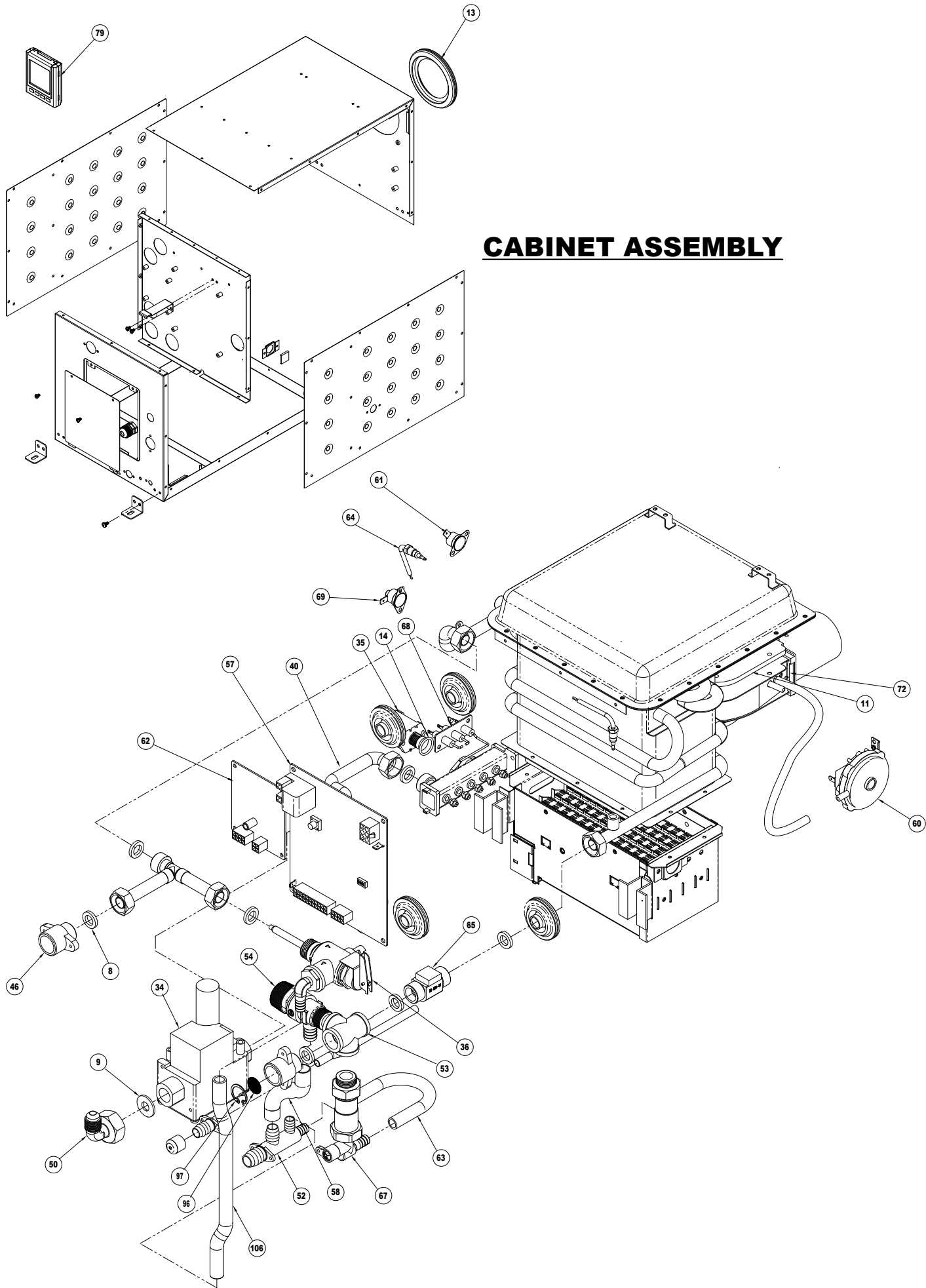

CABINET ASSEMBLY

NAUTILUS (IW60A) PARTS ILLUSTRATION AND PARTS LIST

ITEM NO.	PART NUMBER	DESCRIPTION	QTY.
8	071981	GASKET, RUBBER 1.27 cm (1/2")	6
9	071982	GASKET, RUBBER 1.91 cm (3/4")	3
11	071984	GASKET, BLOWER ASSEMBLY	1
13	071986	GASKET, EXHAUST CABINET	1
14	071991	GASKET, RUBBER SEALING RING	1
34	161248	VALVE, GAS DEMAND WH	1
35	161249	SOLENOID, TWO STAGE REGULATOR	1
36	161266	VALVE, PRESSURE RELIEF	1
40	172002	GAS INLET PIPE ON DEMAND WH	1
46	172044	FITTING, WATER ON DEMAND WH	2
50	172032	FITTING, GAS INLET	1
52	172095	DRAIN, 1.59 cm (5/8) BRASS	1
53	172021	FITTING, INTER 4 WAY JOINT	1
54	172022	VALVE, WATER DRAIN SHUT-OFF	1
57	521135	MODULE BOARD IW60A	1
58	172026	TUBING, FLEXIBLE HOSE	1
60	233229	AIR PRESSURE SWITCH	1
61	233231	SENSOR, OVERHEAT	1
62	521136	MODULE BOARD, BLOWER CONTROLS	1
63	172025	TUBING, FROST PROTECTION DRAIN	1
64	233235	PROBE, TEMPERATURE ON DEMAND WH	2
65	233237	FLOW SENSOR ON DEMAND WH	1
67	233307	VALVE, FREEZE PROTECTION	1
68	233245	ELECTRODE/FLAME PROBE	1
69	233253	SWITCH, LIMIT WITH RESET	1
72	391127	EXHAUST ADAPTER, ON DEMAND WH	1
79A	161271	ON DEMAND CONTROL CENTER (WHITE)	A/R
79B	161272	ON DEMAND CONTROL CENTER (BLACK)	A/R
96	031382	SCREEN, WATER INLET	1
97	063849	CLIP, RETAINER	1
106	172098	TUBING, T&P DRAIN	1



RECREATIONAL VEHICLE WATER HEATER LIMITED WARRANTY

THIS IS A LIMITED 24 MONTH WARRANTY ONLY!!

This water heating product is warranted by Coast to Coast RV Services to the original purchaser to be free from defects in material and workmanship under normal use and maintenance for a period of 24 months from the date of purchase, regardless of the commencement date of use. It is the responsibility of the consumer/owner to establish the warranty period. Coast to Coast RV Services does not use warranty registration cards for its standard warranty. You are required to furnish proof of purchase date through a bill of sale or other payment record.

Coast to Coast RV Services will replace any parts that are found to be defective within the first 24 months and will pay a warranty service allowance directly to the authorized Coast to Coast RV Services approved Agent at rates mutually agreed upon between Coast to Coast RV Services and its authorized service center or agent. Water heater must be returned to a Coast to Coast RV Services authorized service center. Coast to Coast RV Services will not bear costs involving traveling time from their service agents.

Service agents can perform warranty repairs on site but all traveling time will be paid by owner of Vehicle or Caravan.

COAST TO COAST RV SERVICES WILL NOT BE RESPONSIBLE FOR:

1. Normal maintenance as outlined in the installation and operation instructions owner's manual including cleaning of the component parts and cleaning or replacement of the burner orifice. Any water damage arising directly or indirectly from any defect in the water heater or component parts or from its use.
2. Initial check outs and subsequent check outs which indicates the water heater is operating properly or diagnosis without repair.
3. Damage or repairs required as a consequence of faulty or incorrect installation or application not in conformance with installation instructions.
4. Failure to start or operate due to loose or disconnected wire, water or dirt in controls, fuel lines and gas tanks, improper gas pressure or low voltage.
5. Cleaning adjustment of components, electrode, burner tube, pilot and thermocouple.
6. Costs incurred in gaining access to the water heater.
7. Parts or accessories not supplied by Coast to Coast RV Services.
8. Freight charges incurred from parts replacement.
9. Damage or repairs as a consequence of any misapplication, abuse, unreasonable use, unauthorized alteration, improper service, improper operation or failure to provide reasonable and necessary maintenance.
10. Any products whose serial number has been altered, defaced or removed.
11. Damage as a result of floods, winds, lightning, accidents, corrosive atmosphere or other conditions beyond the control of Coast to Coast RV Services.
12. Any special indirect or consequential property, economic or commercial damage of any nature whatsoever.

Some states do not allow the exclusion of accidental or consequential damages, so the above limitation may not apply to you.

NO REPRESENTATIVE, DEALER OR OTHER PERSON IS AUTHORIZED TO ASSUME FOR COAST TO COAST RV SERVICES ANY ADDITIONAL, DIFFERENT OR OTHER LIABILITY IN CONNECTION WITH THE SALE OF THIS WATER HEATING PRODUCT.

For full warranty terms and conditions, please visit www.coastrv.com.au or www.coastrv.co.nz

This warranty gives you specific legal rights. You may also have additional rights which vary from state to state.

IF YOU HAVE A PRODUCT PROBLEM

First: If your RV has its original water heater and is still under the RV manufacturer's warranty. Follow the steps described in the RV owner's manual.

Second: Contact:
Coast to Coast RV Services
PO Box 6287 | Silverwater NSW 1811 Australia
Phone: (02) 9645 7600 | Fax: (02) 9645 7688
Email: warranty@coastrv.com.au