

OPERATING, INSTALLATION, *and* SERVICE MANUAL

FOR INSTALLATION IN RECREATIONAL VEHICLES

NAUTILUS (IW60A) ON DEMAND WATER HEATER DIRECT VENT GAS *with* DIRECT SPARK IGNITION



MANUFACTURED BY AIRXCEL, INC. - SUBURBAN DIVISION

▲ WARNING

Failure to follow safety warning exactly could result in serious injury, death or property damage.

- Do not store or use petrol or other combustible materials or liquids near or adjacent to this water heater or any other appliance. This appliance shall not be installed in any other location where flammable liquids or vapors are likely to be present. **Warning!** This appliance is unsuitable for use as a pool heater.
- **WHAT TO DO IF YOU SMELL GAS**
 - Evacuate all persons from the vehicle.
 - Shut off the gas supply at the gas container or source.
 - Do not touch any electrical switch, or use any phone or radio in the vehicle.
 - Do not start the vehicle's engine or electric generator.
 - Contact the nearest gas supplier or authorized service technician for repairs.
 - If you cannot reach a gas supplier or authorized service technician, contact the nearest fire department.
 - Do not turn on the gas supply until the gas leak(s) has been repaired.
- Installation and service must be performed by authorized installer, service agency or the gas supplier.

▲ FREEZE WARNING

Drain or fill with RV approved antifreeze if subject to freezing temperatures when storing for winter.

▲ WARNING

Installation of this appliance must be made in accordance with the written instructions provided in this manual. No agent, representative or employee of Suburban or other person has the authority to change, modify or waive any provision of the instructions contained in this manual.

Improper installation, adjustment, alteration, service or maintenance can cause injury or property damage. Refer to this manual for assistance or for additional information consult an authorized installer, service agency or gas supplier.

AN ODORANT IS ADDED TO THE GAS USED BY THIS WATER HEATER. THIS APPLIANCE IS NOT INTENDED FOR USE BY YOUNG CHILDREN OR INFIRM PERSONS WITHOUT SUPERVISION. YOUNG CHILDREN SHOULD BE SUPERVISED TO ENSURE THAT THEY DO NOT PLAY WITH THE APPLIANCE.

INSTALLER: AFFIX THESE INSTRUCTIONS TO OR ADJACENT TO WATER HEATER.

OWNER: RETAIN THESE INSTRUCTIONS AND WARRANTY FOR FUTURE REFERENCE.

ALL TECHNICAL AND WARRANTY QUESTIONS SHOULD BE DIRECTED TO THE COMPANY LISTED ON THE WARRANTY OR RATING PLATE WHICH CAME WITH YOUR WATER HEATER.

GAS APPLIANCE REPAIR IS NOT A DO IT YOURSELF TYPE OF REPAIR. ALL REPAIRS SHOULD BE PERFORMED BY A QUALIFIED SERVICE AGENCY.

▲ SAFETY WARNING

Should overheating occur, or the gas supply fail to shut off, shut off the manual gas valve to the appliance before shutting off the electrical supply.

Do not use this appliance if any part has been submerged under water. Immediately call authorized service technician to inspect the appliance and to replace any part of the control system and any gas control that has been submerged under water.

Do not alter the operation of your water heater nor change the design/construction of your water heater. Accessories are being marketed for RV products which we do not recommend. For your safety, only factory authorized parts are to be used on your water heater.

Periodically inspect the vent for obstructions or presence of soot. Soot is formed whenever combustion is incomplete. This is your visual warning that the water heater is operating in an unsafe manner. If soot is present, immediately shut the water heater down and contact your dealer or authorized service person.

When considering add-on rooms, porch or patio, attention must be given to the venting of your water heater. For your safety, do not terminate the vent on your water heater inside add-on rooms, screen porch or onto patios. Doing so will result in products of combustion being vented into the rooms or occupied areas.

Never operate the appliance if you smell gas. Do not assume that the smell of gas in your RV is normal. Any time you detect the odor of gas, it is to be considered life threatening and corrected immediately. Extinguish any open flames including cigarettes and evacuate all persons from the vehicle. Shut off gas supply at LP gas bottle. (See Safety notice on front cover of this manual.)

▲ WARNING

Hydrogen gas may result if you have not used this heater for two weeks or more. HYDROGEN GAS IS EXTREMELY FLAMMABLE. To reduce the risk of injury under these conditions, open the hot water faucet for several minutes at the kitchen sink before you use any electrical appliance connected to the hot water system. If hydrogen is present, you probably will hear an unusual sound such as air escaping through the pipe as the water begins to flow.

Pressure relief valve to be operated at least once every 6 months to remove line deposits and verify it is not blocked. Failure to do so may result in heater exploding. Continuous leakage from valve may indicate a problem with unit.

▲ WARNING

Do not store or use combustible materials or liquids near or adjacent to this appliance. The appliance shall not be installed in any location where flammable liquids or vapors are likely to be present.

▲ WARNING

Be sure the power is "OFF" to the water heater ignition system during any type of refueling and while vehicle is in motion or being towed.

The thermostat on your water heater is adjustable. It is a temperature sensing limit designed to maintain a water temperature from 95°F (35°C) to 122°F (50°C)(See Operating Instructions.) Water temperatures over 125°F (52°C) can cause severe burns instantly or death from scalds; therefore, be careful when using hot water. Children, disabled and elderly are at highest risk of being scalded. Always feel water before bathing or showering.

Servicing shall be carried out only by authorized personnel.

Ensure any transit protection is removed prior to installation.

The appliance is unsuitable for use as a pool heater.

▲ WARNING

For continued safety of this appliance, it must be installed, operated and maintained in accordance with the manufacturer's instructions.

INSTALLATION REQUIREMENTS

⚠ WARNING

Installation of this appliance must be made in accordance with the written instructions provided in this manual. No agent, representative or employee of Suburban or other person has the authority to change, modify or waive any provision of the instructions contained in this manual.

⚠ CAUTION

A Suburban vent cap must be installed on the unit and all side inspection panels must be in place for proper water heater operation.

If possible, do not install the water heater to where the vent can be covered or obstructed when any door on the trailer is opened. If this is not possible, then the travel of the door must be restricted in order to provide a 6" minimum clearance between the water heater vent and any door whenever the door is opened.

Due to the differences in vinyl siding, this appliance should not be installed on vinyl siding without first consulting with the manufacturer of the siding or cutting the siding away from the area around the appliance vent.

In any installation in which the vent of this appliance can be covered due to the construction of the RV or some special feature of the RV such as slide out, pop-up etc., always insure that the appliance cannot be operated by setting the thermostat to the positive "OFF" position and shutting off all electrical and gas supply to the appliance.

Do not install this appliance to where the vent terminates below a slide-out. This appliance is not to be installed under any overhang. It must be free and clear of any type overhang.

A main pressure reducing valve must be installed in the incoming water line with a rating of 350 kPa (50 psi). Please note: Warranty will be void if pressure reducing valve is not installed

This appliance shall be installed only by authorized persons and in accordance with the manufacturer's installation instructions, local gas fitting regulations, electrical wiring regulations, local water supply regulations, AS/NZS 5601, AS/NZS 3500.4 and any other statutory regulations. Refer to AS/NZS 5601 for gas pipe sizing and flueing details.

- A. The appliance shall be disconnected from the gas supply piping system during any pressure testing of the system.
- B. The appliance and its gas connections shall be leak tested before placing the appliance in operation.
- C. All air for combustion must be supplied from outside the structure. Air for combustion must not be supplied from occupied spaces.
- D. Minimum clearance from combustible construction 0" (0mm). Provide room for access to front of water heater and at left side for servicing.
- E. Choose a location for installation out of the way of wires, pipes, etc. that might interfere with the installation.
- F. When an appliance is installed directly on carpeting, tile or other combustible material, other than wood flooring, the appliance shall be installed on a metal or wood panel the full depth of the appliance. If preferred the carpeting, tile or combustibles materials, other than wood may be cut away the full length of the appliance plus the appliance minimum clearances to combustibles.
- G. Good grounding of the unit is recommended to mitigate static charge built up by attaching a 12 gage ground wire to the unit case at the green grounding screw shown in **Figure 5A** and securely fasten the ground wire to the RV metal frame.
- H. Do not install the water heater with the vent facing toward the forward end of the coach. See **Figures 1, 2 and 3**.
- I. There must be access for removing unit for service.

TECHNICAL DETAILS

- | | |
|--------------------------|----------------------|
| 1. Injectors: | 1.05mm x2, 1.10mm x3 |
| Nominal Gas Consumption: | 64 MJ/h |
| Test Point Pressure: | 1.89 kPa |
| Type of Gas: | Universal LPG |
2. Width: 12.47" (316.6mm)
Height: 12.51" (317.8mm)
Depth: 18.3" (464.9mm)
 3. Location of hot water outlet is 1.34" (34mm) from top dead center.
Location of cold water inlet is 5.07" (128.7mm) from bottom dead center.
Location of flue outlet is 3.98" (101mm) from RH top edge of unit.
Location of gas inlet connection point is 2.40" (61mm) in from the left hand edge of the unit.
 4. Size of inlet 3/8"

INSTALLATION WITHOUT REPLACEMENT PANEL

1. Locate area for installation of the unit. The unit should be installed as close to wall as possible. Mark wall as shown in **Figure 4** and cut a 3 3/4" (95.3mm) Diameter hole for vent installation. On mesa or yoder type side walls, it may be required to flatten area where vent is to be installed to assure seal around vent assembly.
2. Place unit on floor (verify vent cap lines up with exhaust tube and combustion air opening in unit).
 - a. Drain lines must be connected to the system and condensation drains on the On Demand Water Heater and ran to the outside of the RV. Drain Lines should be as short as possible and must maintain a drop of 1/4" (6.4mm) per foot from unit. See **Figure 5A**.
3. Install vent assembly. See **Figure 6**.
 - a. Vent cap must be ordered separately. See **TABLE 1** for vent sizes and part numbers. A minimum overlap of 1 1/4" (32mm) is required on exhaust.
 - b. Apply a bead of silicone around the vent cap as shown in **Figure 6**.
 - c. Install vent cap as shown in **Figure 6** with screws. Insure assembly is sealed to outside wall to prevent leaks.
4. Screw the front of the unit to the floor using the two brackets as shown in **Figure 5A**. If necessary, the brackets can be moved to the rear of the unit as shown in **Figure 7B**.
5. Make electrical, drain, water and gas connections following instructions contained in this manual or the manual supplied with the Suburban NAUTILUS (IW60A) On Demand Water Heater.

INSTALLATION USING REPLACEMENT PANEL

A replacement panel is used when replacing Suburban 6, 10, 12, and 16 gallon tank units and Atwood Style 6 and 10 gallon tank units.

1. On mesa or yoder type sidewalls, flatten the wall area around the opening.
2. Apply a continuous line of suitable caulk on the RV wall around all four sides of the opening and around back side of replacement panel frame as shown in **Figure 8**. Required to create water tight seal of the frame to the RV wall.
3. Center and insert caulked replacement panel frame into opening. Push frame firmly against RV wall over caulking previously applied in step 2. Secure frame with the eight (8) supplied screws into RV wall as shown in **Figure 8**.
4. Locate the water heater cabinet approximately even with the inside RV wall. See **Figure 7B**. If securing the unit to the floor using the FRONT mounting brackets, proceed to STEP 5. To mount the water heater using the REAR mounting method, remove the two mounting brackets from the front of the unit and secure them to the threaded holes at the rear of the unit. Screw the rear of the unit to the floor using the two brackets. See **Figure 7B**.
5. Using the gasket supplied with the kit, apply the gasket beginning at the center bottom of the replacement panel frame. Adhere the adhesive side of the gasket to the replacement panel frame and install the gasket all the way around the frame. Insure the ends of the gasket meet at the center bottom of the replacement panel frame.
6. Attach the replacement panel to the frame as shown in **Figure 8** using the five (5) screws provided.
7. Vent cap must be ordered separately. See **Table 1** for vent sizes and part numbers. There must be a minimum of 1.25" (31.8mm) overlap of vent assembly tube over exhaust tube on the On Demand Water Heater and the replacement panel must compress the replacement panel gasket. See **Figure 7A**.
 - a. Apply a bead of silicone around the vent cap as shown in **Figure 8**.
 - b. Install vent cap as shown in **Figure 8** with four (4) screws. Insure assembly is sealed to outside wall to prevent leaks.
8. Screw the front of the unit to the floor using the two brackets as shown in **Figure 5A**.
9. Apply silicone caulk around the beveled edges of the replacement panel as shown in **Figure 8**. Do not caulk the bottom of the replacement panel.
10. Make electrical, drain, water and gas connections following instructions contained in this manual or the manual supplied with the Suburban NAUTILUS (IW60A) On Demand Water Heater.

REPLACEMENT PANEL PART NUMBERS		
BRAND	CAPACITIES	PART NUMBER
SUBURBAN	6 GALLON	6276APW (Polar White)
SUBURBAN	10, 12, 16 GALLONS	6277APW (Polar White)
ATWOOD	6 GALLON	521147 (Polar White)
ATWOOD	10 GALLON	521150 (Polar White)

VENT CAP PART NUMBER	VENT CAP LENGTH	"X" MAX DIMENSION
260616	0-1" (0 - 25.4mm)	1.17" (29.7mm)
260617	1-2" (25.4 - 50.8mm)	2.17" (55.1mm)
260618	2-3" (50.8 - 76.2mm)	3.17" (80.5mm)
260638	5-6" (127 - 152.4mm)	6.17" (156.7mm)

TABLE 1

MAKING ELECTRICAL CONNECTIONS

12 VOLTS D.C. (SEE FIGURE 11)

- The electrical connection must be made to conform with the local authority having jurisdiction or in the absence of such requirement with the latest Australian electrical code.
- Make the 12 Volt D.C. electrical connections following the wiring diagram illustrated in Figure 11.

If the power supply is to be from a converter, we recommend that the converter system be wired in parallel with the battery. This will serve two purposes:

- Provide a constant voltage supply
- Filter any A.C. spikes or volt surges

We recommend insulated terminals be used for all electrical connections.

INSTALLATION OF ON DEMAND CONTROL CENTER (SEE FIGURE 13)

⚠ WARNING

Do not use on circuits exceeding specified voltage. Higher voltage will damage Control Center and could cause shock or fire hazard. Do not short out terminals on gas valve or primary control to test. Short or incorrect wiring will damage thermostat and could cause personal injury and/or property damage.

- On Demand Control Center is wired as shown in wiring diagram. See Figure 11.
- Locate the On Demand Control Center on a wall surface adjacent to the On Demand Water Heater.
- Remove back cover from Control Center by depressing latch at bottom.
- Remove center knockout from back cover. Drill hole for wiring from Control Center. See Figure 13.
- Mount back cover to the wall.
- Route wiring through back cover and hole into wall.
- Connect the two white wires from the On Demand Control Center to the two white wires from the On Demand Water Heater. See Figure 11.

The On Demand Control Center displays the setpoint water temperature and also allows outlet water temperature to be adjusted from 35°C/95°F to 50°C/122°F.

ON DEMAND CONTROL CENTER	PART NUMBER
WHITE	161271
BLACK	161272

MAKING DRAIN CONNECTIONS (SEE FIGURE 5A)

- Drain connections are made at the front of the water heater. Refer to Figure 5A. Connect 5/8" ID hose to system drain fitting provided on front of unit. Connect 1/2" ID hose to condensation drain fitting provided on front of unit.
- Drain lines must run to the outside of the RV. Drain lines should be as short as possible and must maintain a minimum drop of 1/4" per foot. (6.4mm per 305mm). See Figure 5A.

MAKING WATER CONNECTIONS (SEE FIGURE 5A, 5B)

⚠ WARNING

This appliance delivers water not exceeding 50°C in accordance with AS 3498. Refer to AS/NZS 3500.4, local requirements and installation instructions to determine if additional delivery temperature control is required.

- Water connections are made at the front of the water heater. Refer to Figure 5A.
- PIPE SIZES** - The pipe sizing for hot water supply systems should be carried out by persons competent to do so, choosing the most suitable pipe size and pipe routing to ensure adequate flow for each individual application. To achieve good flow performance, the cold water line to the water heater should be the same size or larger than the hot water line from the water heater. The minimum recommended cold and hot water supply pipe size is 1/2" (12mm). Refer to Figure 5B.
- Connect the hot and cold water lines to the 1/2" BSPT female pipe fittings provided on front of unit. These fittings are marked "HOT" and "COLD".
 - IMPORTANT:** Use a pipe thread compound suitable for potable water or pipe thread tape on all connections to assure they will not leak.
 - For ease of removal, it is suggested that a pipe union be installed in each water line.
- Fill system with water. Open both hot and cold water faucets to expel air from system. When system is filled and water flows from faucets, close both faucets and check all connections for leaks.

MAKING GAS CONNECTIONS

- Connect a 3/8" gas supply line to the 3/8" flare fitting at gas valve. When making the gas connection, hold the gas fitting on the water heater with a wrench when tightening the flare nut. Failure to hold fitting securely could result in a gas leak due to fitting being damaged.
 - Turn on gas and check all fittings and connections for leaks using a soap and water solution. Correct even the slightest leak immediately.
- NOTE:** When replacing your water heater with an IW60A On Demand Water Heater, review your gas regulator to ensure it can maintain a proper gas flow during the operation of the On Demand Water Heater and other gas burning appliances.
- NOTE:** Regulator switch over pressure may be lower than main operating pressure. Refer to AS5601 for gas pipe size.

⚠ WARNING

Before leaving - Check all connections for gas leaks with soap and water. DO NOT use a naked flame for detecting leaks. Ignite the burner at high and low setting to ensure correct operation of controls, burners and ignition. Set to low flame position and observe stability of the flame for each burner individually and concurrently. When satisfied with the installation, please instruct the user on the correct method of operation. In case the appliance fails to operate correctly after all checks have been carried out, refer to the authorized service provider in your area.

OPERATING SAFETY INFORMATION FOR YOUR SAFETY READ BEFORE OPERATING

⚠ WARNING

If the user of this appliance fails to maintain it in the condition in which it was shipped from the factory or if the appliance is not used solely for its intended purpose or if appliance is not maintained in accordance with the instructions in this manual, then the risk of a fire and/or the production of carbon monoxide exists which can cause personal injury, property damage or loss of life.

If you do not follow these instructions exactly, a fire or explosion may result causing property damage, personal injury or loss of life.

- This appliance does not have a pilot. It is equipped with an ignition device which automatically lights the burner. Do not try to light the burner by hand.
- BEFORE OPERATING**, smell all around the appliance area for gas. Be sure to smell next to the floor because some gas is heavier than air and will settle on the floor.

WHAT TO DO IF YOU SMELL GAS

- Evacuate all persons from the vehicle.
 - Shut off the gas supply at the gas container or source.
 - Do not touch any electrical switch, or use any phone or radio in the vehicle.
 - Do not start the vehicle's engine or electric generator.
 - Contact the nearest gas supplier or authorized service technician for repairs.
 - If you cannot reach a gas supplier or authorized service technician, contact the nearest fire department.
 - Do not turn on the gas supply until the gas leak(s) has been repaired.
- C. This unit has an automatic gas valve, no adjustments are necessary. Do not attempt to repair the gas valve. This may result in a fire or explosion.
- D. Do not use this appliance if any part has been under water. Immediately call an authorized service technician to inspect the appliance and to replace any part of the control system and any gas control which has been under water.
- E. Before operating water heater, check the location of the vent to make sure it will not be blocked by the opening of any door on the trailer. If it can be blocked, do not operate the water heater with the door open.

OPERATING INSTRUCTIONS FOR THE ON DEMAND CONTROL CENTER(SEE FIGURE 12)

1. **STOP!** Read the safety information above.
2. Turn off all electric power to the appliance.
3. Turn "OFF" gas supply.
4. Wait five minutes for gas to clear the area. If you smell gas then STOP! Follow instructions in item **B** of the **SAFETY INFORMATION**. If you do not smell gas, go to next step.
5. Turn "ON" gas supply.
6. Turn on electrical power to the appliance.
7. PRESS THE "ON" button. The On Demand Control Center is illustrated in **Figure 12**. Your On Demand Control Center is located somewhere inside the RV. There must be a hot water faucet OPEN to a minimum of 1.9 LPM for the unit to operate. If the burner does not light, the system will automatically attempt two more tries for ignition before lock-out.
8. If lockout occurs, an ERROR CODE will be displayed on the On Demand Control Center and the unit must be re-cycled by turning the faucet OFF or by pressing the OFF button on the On Demand Control Center and then back ON. The first start-up of the heater may require several ignition cycles before all air is purged from the gas lines.

To change the water temperature settings:

1. Press the UP or DOWN arrows on the On Demand Control Center to increase or decrease the SET water temperature in single degree increments. The water temperature set range is 35°C/95°F to 50°C/122°F. See **Figure 12**.

SEQUENCE OF OPERATION

1. Turning on a hot water faucet activates the On Demand Water Heater.
2. The water heater senses the flow of water.
3. The water heater proves that the combustion air fan is working.
4. The combustion chamber is then purged of any remaining raw gas.
5. The burner will ignite and prove the flame.
 - a. The approximate time from turning on the faucet to ignition is 7 seconds. After the initial lighting sequence and the water heater is maintaining temperature, the ignition cycle is reduced to approximately 5 seconds.
 - b. Burners will stay ON until the water flow is shut off.
6. The flow of hot water at the SET point begins approximately 3 seconds after ignition but will not reach the faucet until the hot water lines leading to the faucet are cleared of any remaining water. This time is determined by the length of the hot water line.
7. When the hot water faucet is turned OFF, the water heater shuts down and will remain in a ready state until hot water is called for again.

NOTE: Blower motor will operate for approximately 20 seconds after the hot water faucet is turned OFF.

8. The On Demand Control Center can be left in the ON position and no further action is required by the user.
9. If the water heater fails to light for any reason, a second Trial For Ignition(TFI) will automatically begin. If the second Trial For Ignition(TFI) fails, the water heater will automatically begin a third Trial For Ignition(TFI). If the third Trial For Ignition(TFI) fails, the water heater will go into a lock out mode and will not try to light the burner again. To reset:
 - a. Turn faucet OFF, then back on.

NOTE: The NAUTILUS (IW60A) On Demand Water Heater has an energy mode circuit that will shut down operation if operating continuously for three (3) hours. To reset, follow the instruction in STEP 9A above.

NOTE: Air in the gas line after changing propane tanks is the main reason for not lighting the burner. A simple method to remove air from the gas line is to ignite a burner on the installed cooking appliance inside your RV.

OPERATING FAUCETS and SHOWER with the NAUTILUS (IW60A) ON DEMAND WATER HEATER

- A. All faucets must be operated the same as you would in your home.
- B. Cold water must be added to achieve the desired hot water temperature.
 1. If this is the first use of the unit for the season, turn water supply on and open each faucet and allow all air to be purged from the water lines.
 2. Turn ON power supply.
 3. Turn ON propane supply. Hot water faucet may have to be cycled several times to purge gas supply.
- C. The water heater only heats when there is a call for water (open hot water faucet).
- D. A minimum of 0.5 gpm(1.9 Lpm) is required for water heater to operate.
- E. Faucet should be turned on and adjusted to desired temperature and flow before entering shower.
- F. Showerhead button should NOT be used. Using the showerhead button will create a drop in temperature by reducing or stopping the flow of water through the water heater causing the water heater to shut down.

TO TURN OFF THE ON DEMAND WATER HEATER

1. Press the On Demand Control Center power button once.
2. Turn off electrical power to the appliance.
3. Turn off gas supply.
4. If vehicle is to be stored or heater is going to be turned off while subject to freezing temperature, drain water heater. (See "Draining and Storage Instructions.")

OPERATIONAL TROUBLESHOOTING

⚠ CAUTION

For your safety, ALL repairs and/or maintenance of unit should be performed by your dealer or an authorized service technician.

NOTE: There must be a demand of at least 0.5gpm(1.9Lpm) for the burner to operate and allow water flow. This will continue until the water flow is turned OFF and the system goes dormant.

NO WATER FLOWS FROM FAUCET WHEN TURNED ON:

1. Be sure water supply is turned ON and there are no water restrictions.

BURNER TURNS ON, TEMPERATURE FLUCTUATES ERRATICALLY:

1. Clean all shower heads, faucet aerators or water strainers as required and remove any flow restrictions to assure the minimum 0.5gpm(1.9Lpm) of water flow.

ON DEMAND HEATER COMES ON AND RAPIDLY CYCLES ON AND OFF:

1. Water flow is too low. Increase flow at faucet.
2. Clean all shower heads, faucet aerators or water strainers as required and remove any flow restrictions to assure the minimum 0.5gpm(1.9Lpm) of water flow.
3. Verify the water pump is functioning properly.
4. Bleed air out of plumbing lines by opening all water faucets.
5. If the On Demand Water Heater cycles as the pump cycles, an accumulator tank is needed in the water system. If accumulator tank is already installed, check for water inside the tank and drain tank until only air is present.
6. Water source pressure fluctuates too low causing loss of flow. Check the incoming water source for a minimum of 30 psi(207 kPa).

WATER TEMPERATURE IS TOO LOW WITH LOWER WATER FLOW:

1. Water flow is too low. Increase flow at faucet to assure the minimum 0.5gpm (1.9Lpm) of water flow.

WATER TEMPERATURE IS TOO HIGH OR NO TEMPERATURE CONTROL:

1. Press the UP or DOWN arrows on the On Demand Control Center to increase the SET water temperature in single increments. Refer to **OPERATING INSTRUCTIONS FOR THIS ON DEMAND Control Center** and see **Figure 13**.

LOW TEMPERATURE RISE AND EXCESSIVE WATER FLOW REQUIRED TO TRIGGER THE ON DEMAND WATER HEATER:

NOTE: If you find that your water heater requires excessive flow to activate it (over 0.8gpm(3.0Lpm)), it is possible that you have COLD water bleeding into the HOT water side of your water system.

1. Verify that valves and faucets are closed when not in use. Check the shower head for an ON/OFF button/lever and ensure it is in the OFF position to prevent cold water from bleeding into the hot water system. This can keep the On Demand Water Heater from functioning correctly.
2. If your RV is equipped with a bypass valve at the water plumbing connection, make sure it is in the OFF position. An open valve can allow water to bypass water heater causing a failure to ignite.

NO IGNITION:

If the burner will not come on, the following items should also be checked before calling a service technician:

- A. On Demand Control Center is turned off.
- B. 12 VDC power is OFF
- C. Check gas supply is available to the water heater.
- D. Water turned on and faucet open.
- E. Check manual reset on ECO switch. Refer to **DETAIL "A" in Figure 9**.

If burner fails to light, call a local RV service agency.

MAINTENANCE

⚠ WARNING

If the user of this appliance fails to maintain it in the condition in which it was shipped from the factory or if the appliance is not used solely for its intended purpose or if appliance is not maintained in accordance with the instructions in this manual, then the risk of a fire and/or the production of carbon monoxide exists which can cause personal injury, property damage or loss of life.

For your safety, all repairs should be performed by your dealer or an authorized service person.

- A. Periodically inspect unit for soot. If soot is present anywhere on water heater, immediately shut unit down and contact your dealer or an authorized service person. Soot is a sign of incomplete combustion and must be corrected before operating water heater. Areas to check would include:
1. Check for an obstruction in vent cap.
 2. Check vent to see that no foreign material has accumulated to prevent flow of combustion and ventilating air.
 3. Check to be sure there is no flame present at burner orifice or burner whenever main gas valve is closed.
- B. Periodically check wiring and wire connections to be sure wiring is not damaged/frayed and that all terminals and connections are tight and in compliance with codes (See "Making Electrical Connections").

DRAINING AND STORAGE INSTRUCTIONS

If RV is to be stored during winter months, the water heater system must be drained to prevent damage from freezing.

1. Turn off electrical power to water heater.
2. Shut off gas supply to water heater.
3. Turn off pressure pump on water system.
4. Open both hot and cold water faucets.
5. Remove Service Panel to access system drain valve.
6. Turn drain valve knob clockwise to drain.
7. Follow RV manufacturer's instructions for draining entire water system.

NOTE: System will have to be refilled with water and all air removed from lines before unit will re-light.

NOTE: All water must be drained to the outside of the RV - Drain lines must be connected to the system and condensation drains on the water heater and ran to the outside of the RV. Drain Lines should be as short as possible and must maintain a drop of 1/4" per foot(10mm per .05m) from unit. **See Figure 10.**

WINTERIZING

1. Follow RV manufacturer's instructions for draining entire water system.
2. Once drained, RV NON-TOXIC antifreeze can be added if recommended by your coach manufacturer.

FREEZE PROTECTION

The NAUTILUS (IW60A) On Demand water heater has built-in FREEZE PROTECTION and will intermittently cycle the burner when the water temperature has fallen below 40°F(4.4°C). This intermittent cycling will continue until the water temperature has risen above 50°F(10.0°C). To provide this freeze protection, the gas supply must be on, gas must be available and electrical power must be on.

If the On Demand Water Heater is dripping water into the drain line in cold weather, when the water supply temperature is below 38°F(3.3°C) and does not stop when the water temperature rises above 38°F(3.3°C), call your local service center. The valve may be disabled by turning the needle valve located on the front of the On Demand Water Heater 5 and 1/2 turns clockwise. Closing the valve will disable the mechanical freeze protection feature. The water system must be drained when not in use to avoid damage caused by ice expanding in water lines if valve is closed.

DESCALING INFORMATION

Each year, drain the water from the system and flush the heat exchanger with an approved descaling solution.

PRESSURE RELIEF VALVE

The temperature and pressure relief valve is designed to open if the temperature of the water within the heater reaches 210°F(99°C), or if the water pressure in the heater reaches 145psi(1 MPa).

⚠ WARNING

Do not place a valve between the relief valve and the unit. Do not plug the relief valve under any circumstances.

Suburban recommends that a check valve not be installed directly at the inlet to the water heating unit.

⚠ WARNING

Do not remove or plug the relief valve.

REMOVING ON DEMAND WATER HEATER

1. Shut off gas supply and disconnect gas supply line from water heater.
2. Disconnect 12 V.D.C. power supply to heater.
3. Shut off water supply. Drain water from system.
4. Disconnect HOT and COLD water lines from water heater.
5. Remove screws at the back of the unit.
6. Remove vent cap assembly.
7. Remove water heater. To reinstall, follow installation instructions provided in this manual beginning on page 3.

⚠ WARNING

For your safety, ALL repairs and/or maintenance of unit should be performed by your dealer or a qualified service technician.

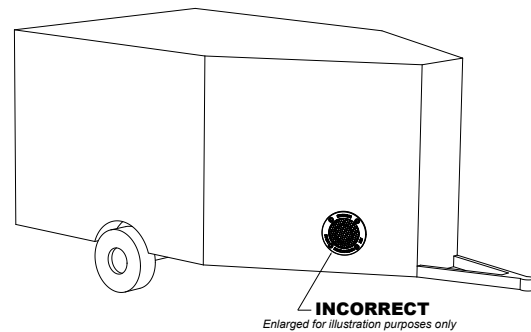

Figure 1

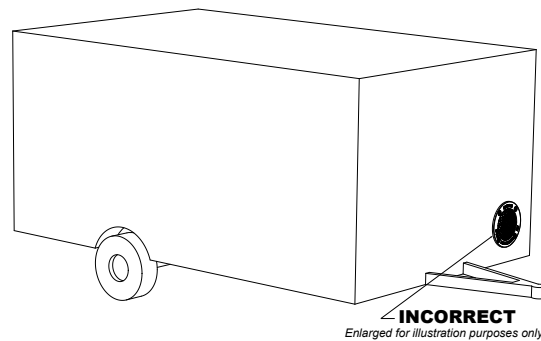

Figure 2

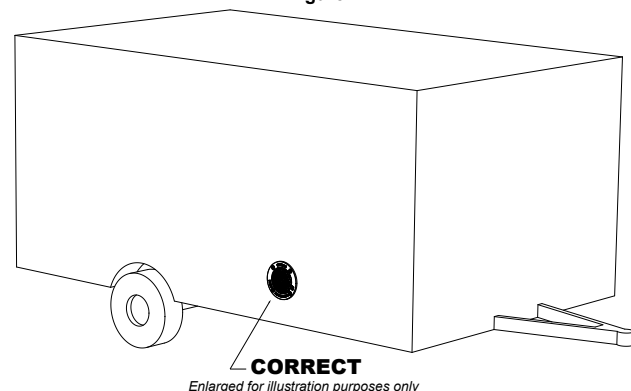

Figure 3

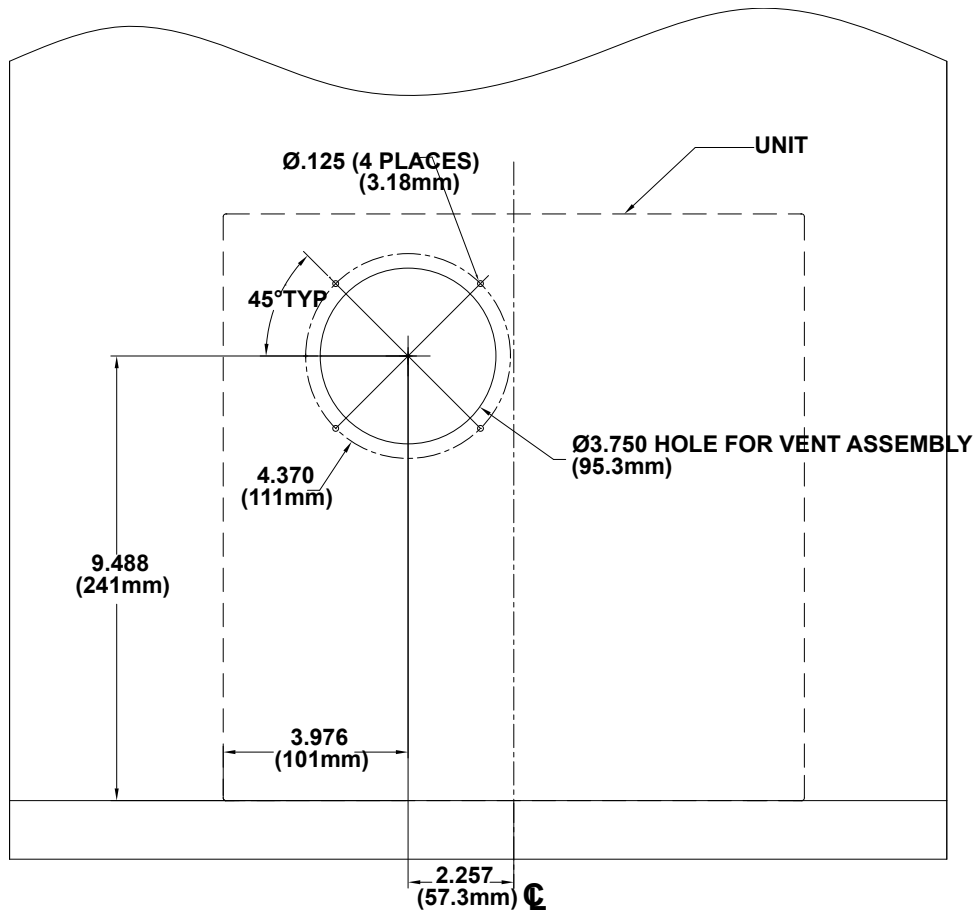

Figure 4

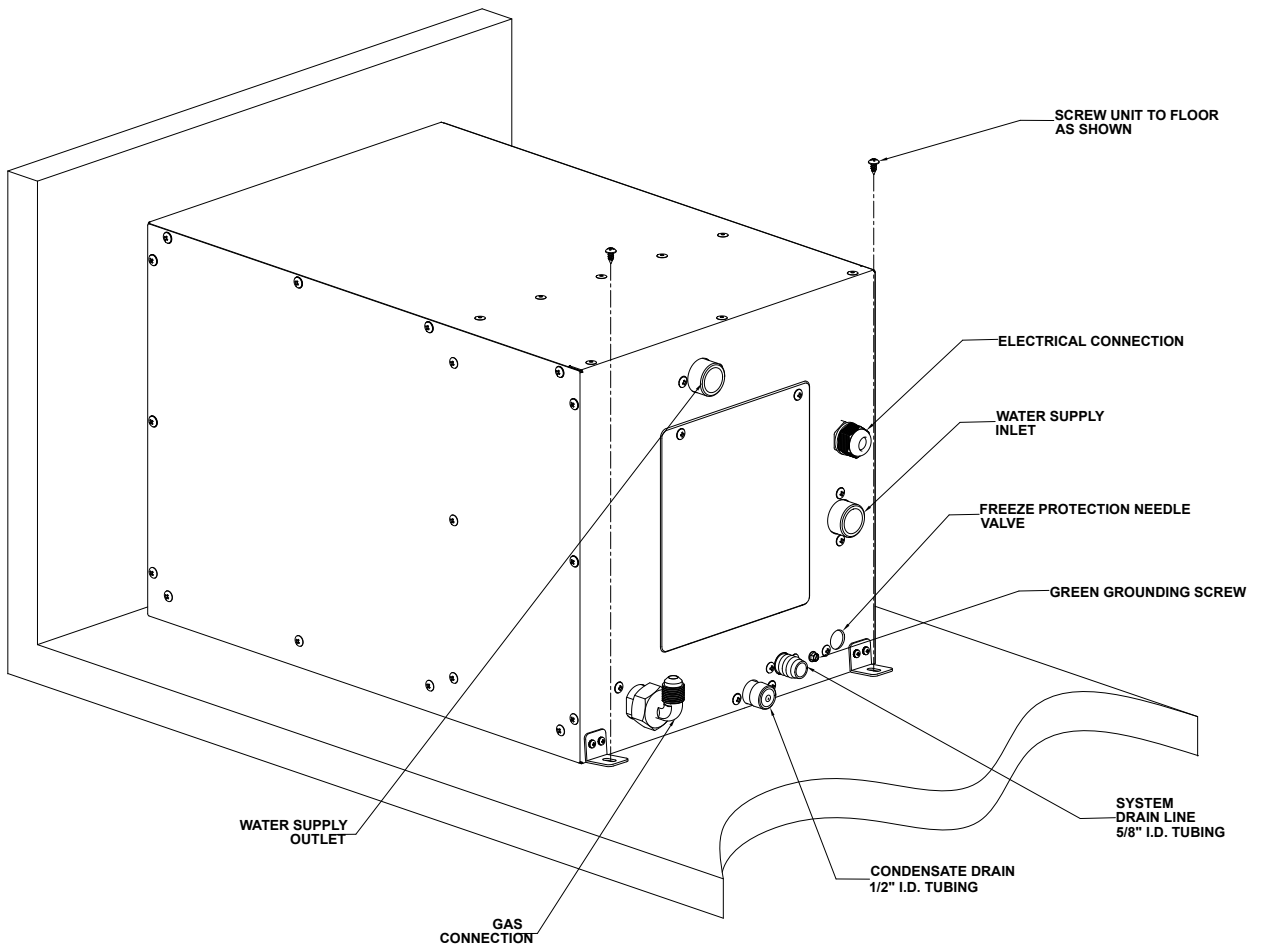

Figure 5A

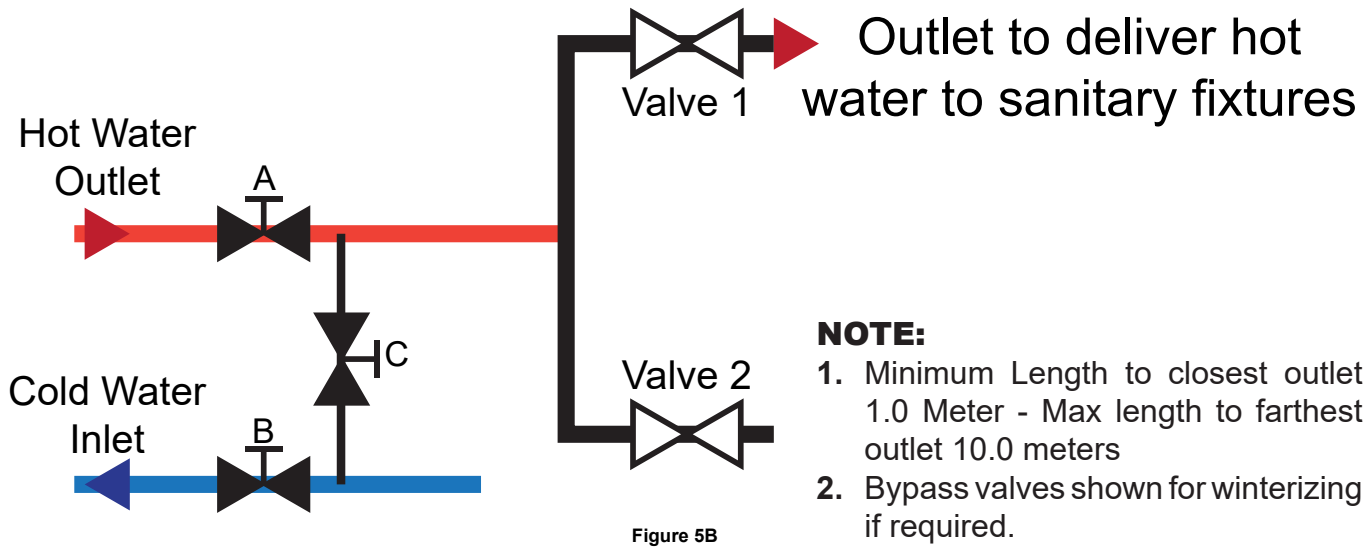

Figure 5B

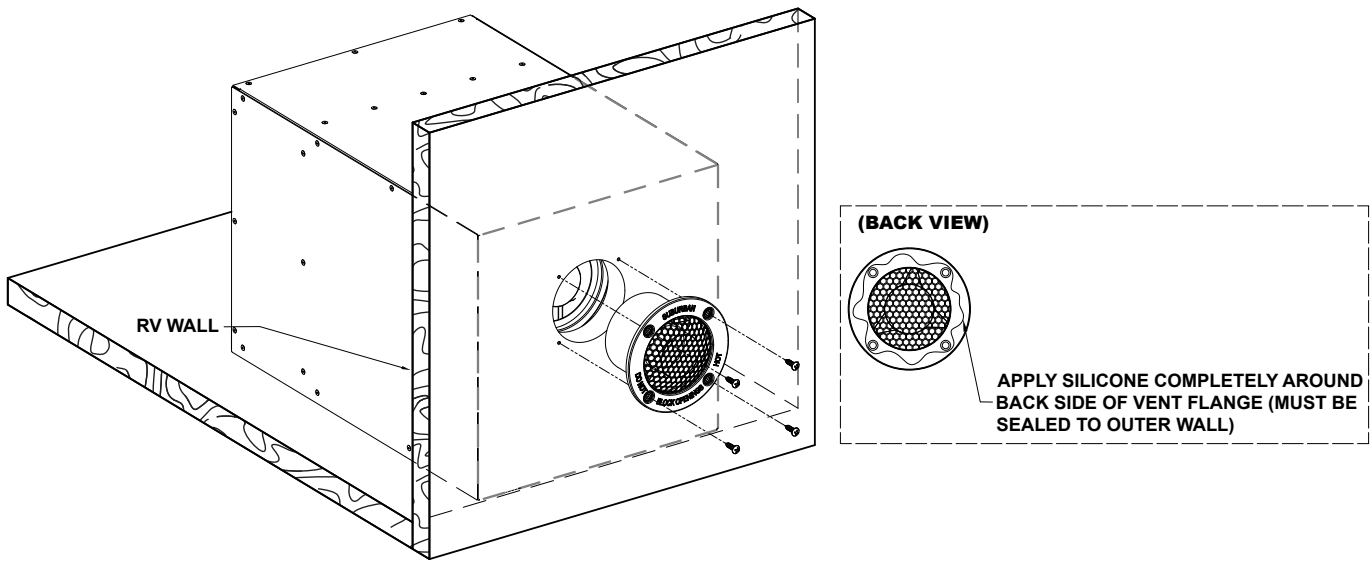

Figure 6

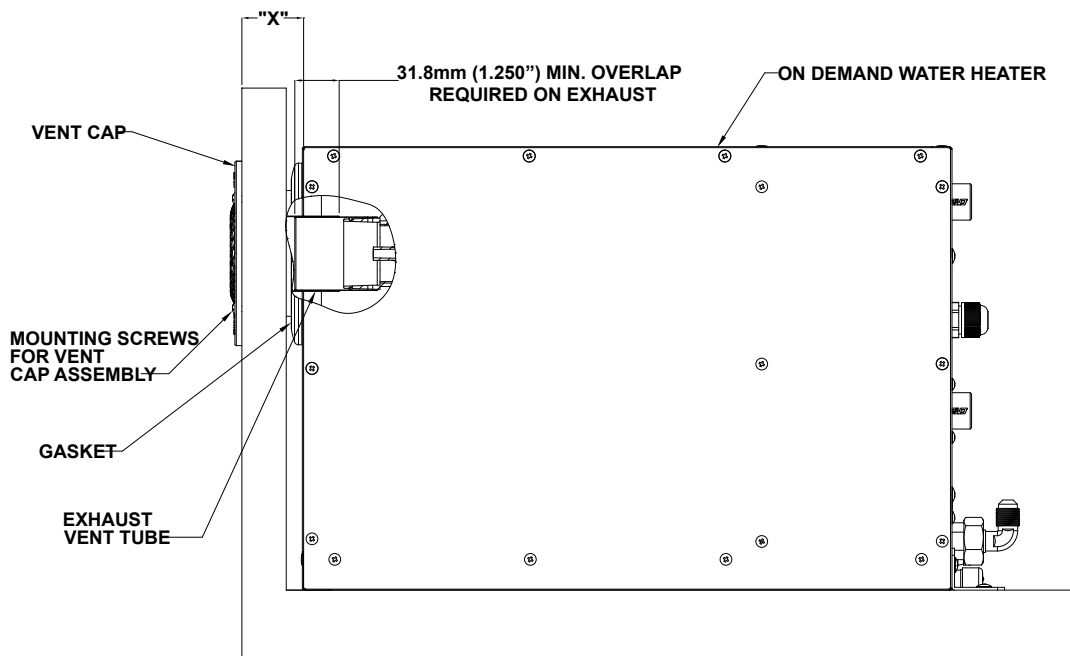
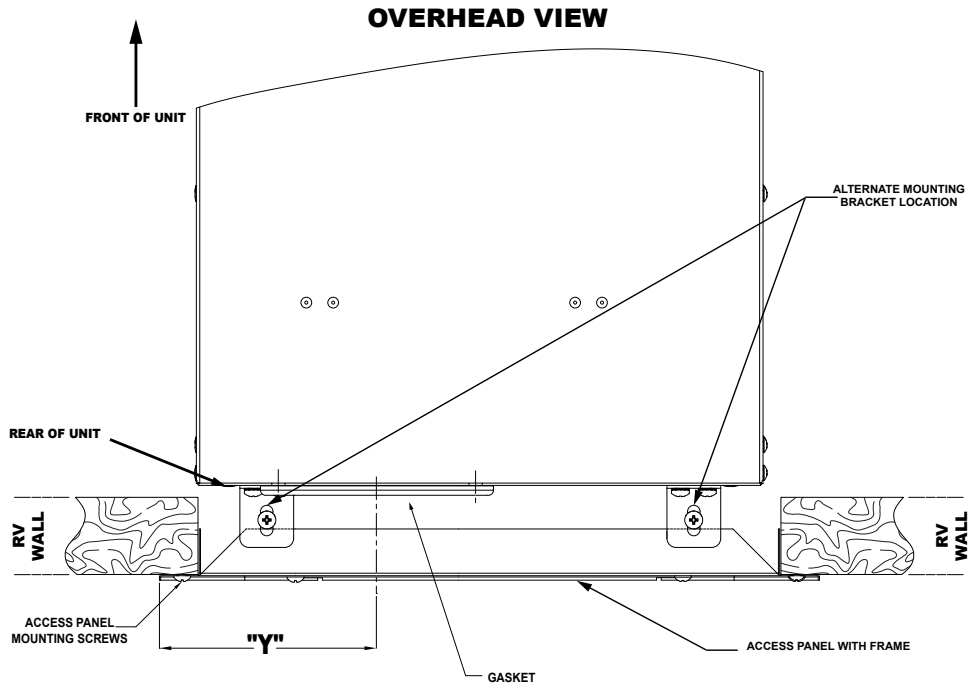

Figure 7A



SUBURBAN REPLACEMENT PANEL	"Y" DIMENSION
6 GALLON	4.895"(124.3mm)
10 GALLON	6.634"(168.5mm)

Figure 7B

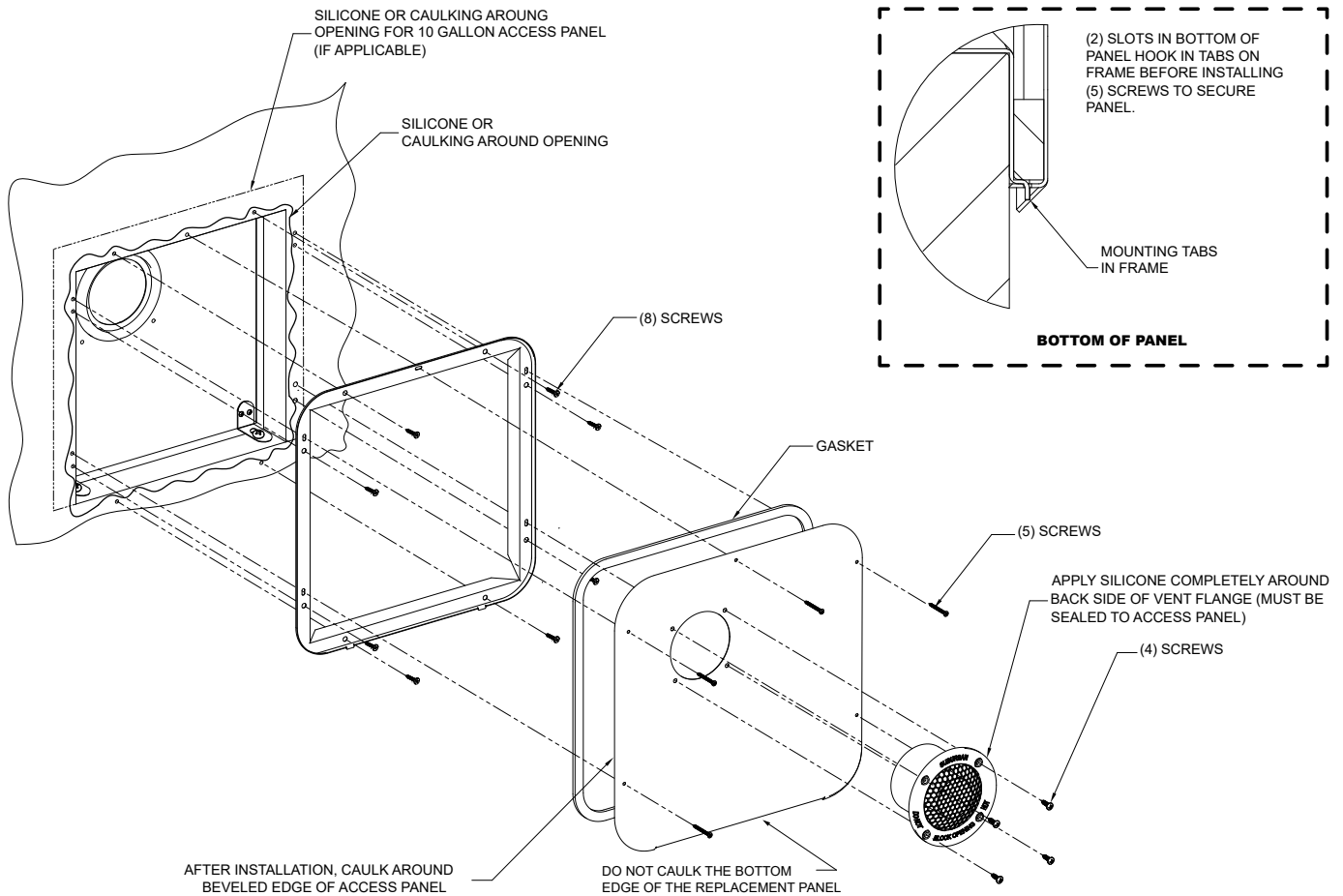

Figure 8

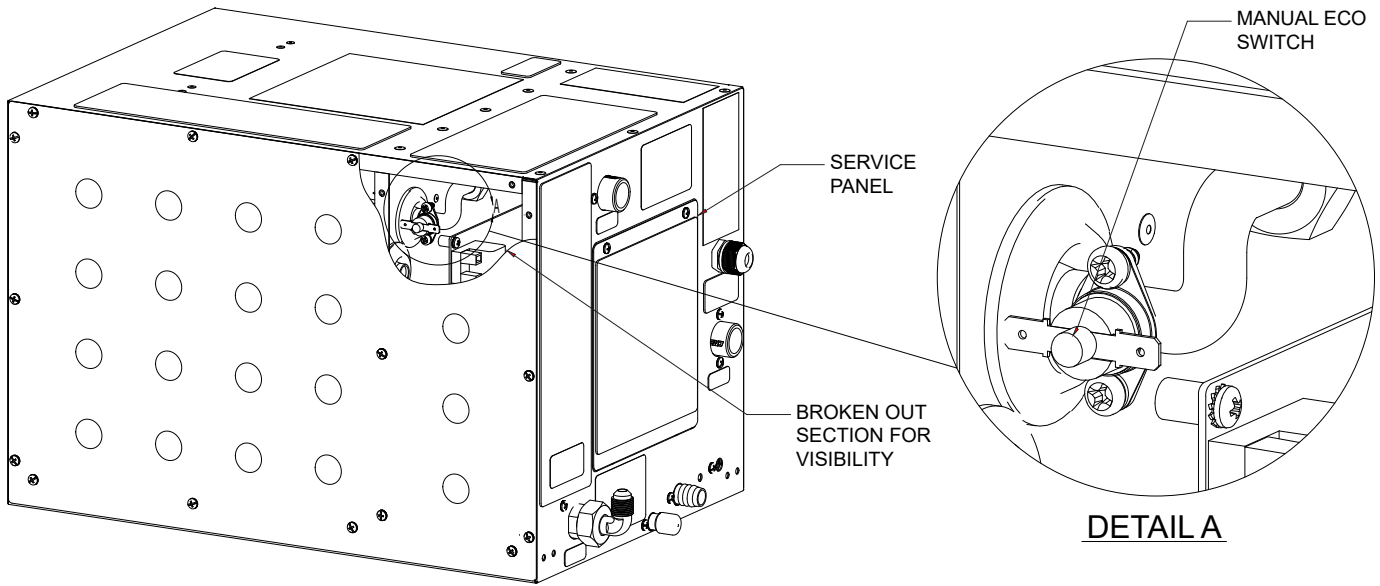

Figure 9

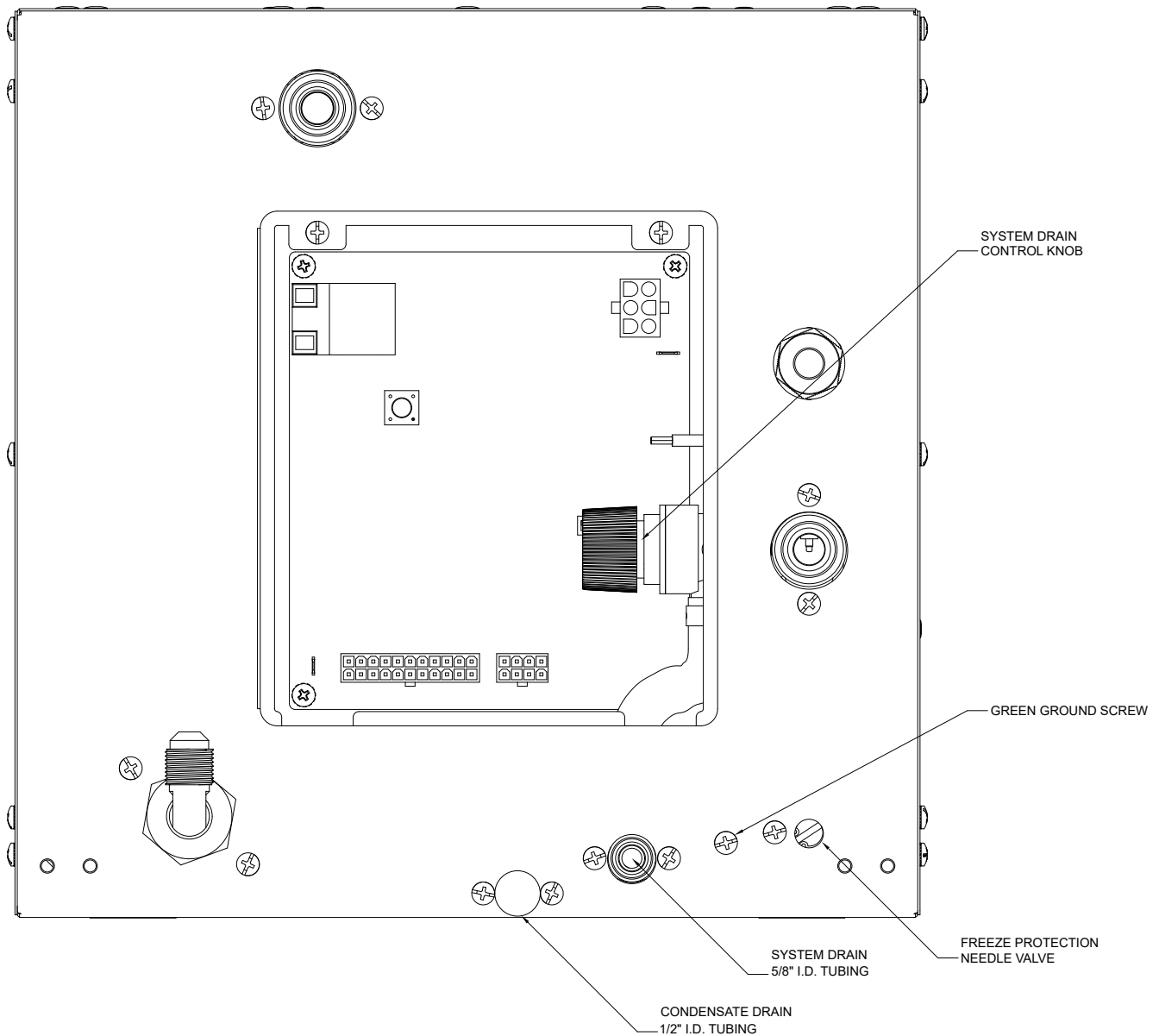

Figure 10

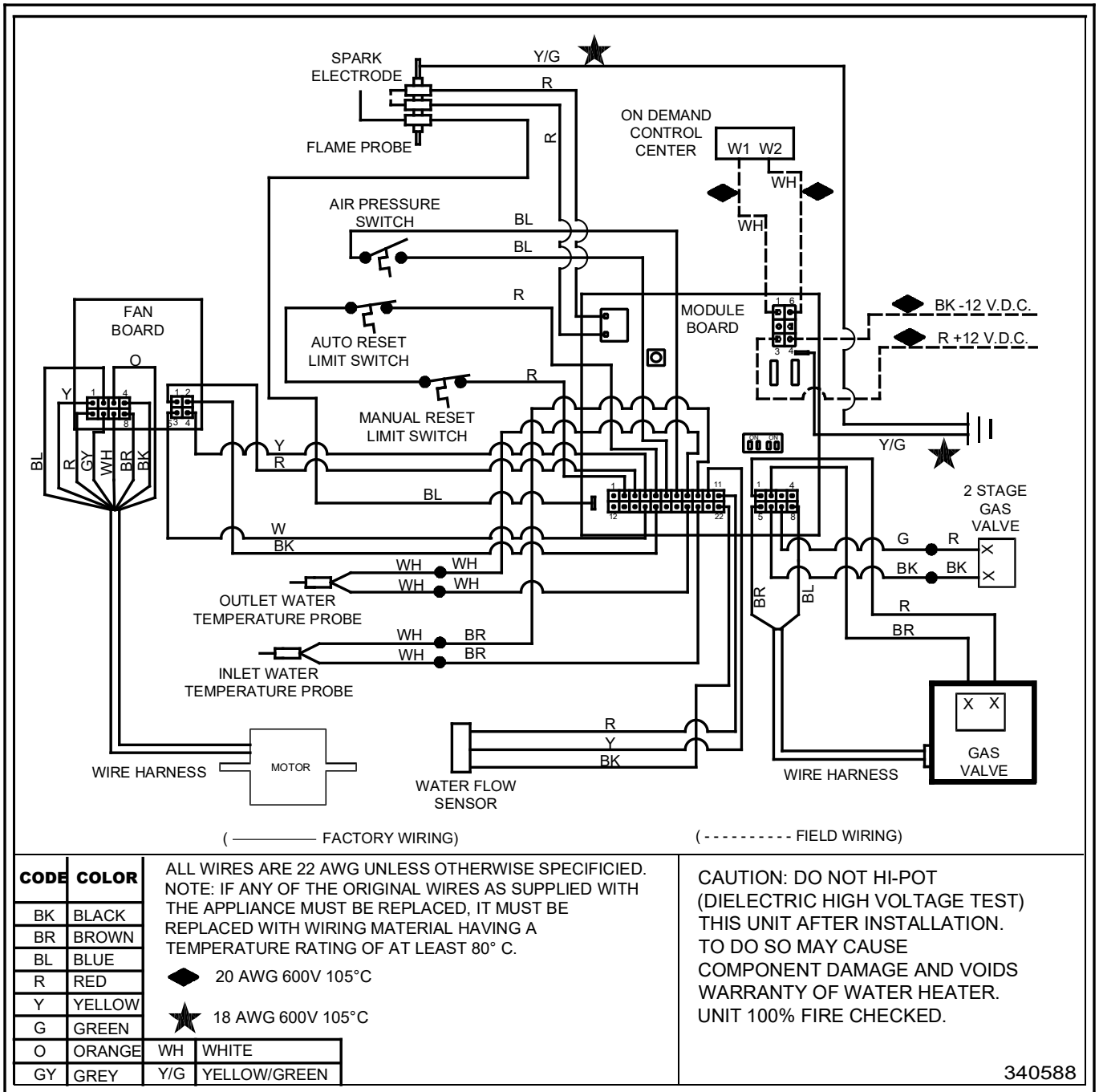

Figure 11

ON DEMAND CONTROL CENTER

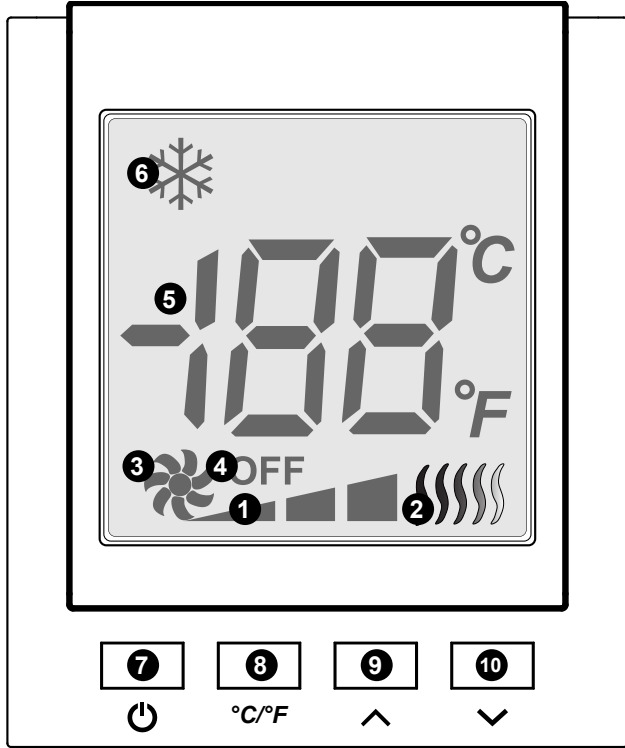

Figure 12

DISPLAY DESCRIPTION

1		BURNERS		2 BURNERS 5 BURNERS
2		FLAME	This icon is displayed when FLAME is established.	
3		BLOWER	This icon is displayed when the BLOWER is running	
4	OFF	STATUS INDICATOR	This icon is displayed when the Water Heater is in standby mode, ready to be used.	
5		SETTING TEMP INDICATOR; OUTLET WATER TEMP INDICATOR	<p>A. When setting the water temperature, the temperature display will flash. After SET Temperature is reached, the display stops flashing after a few seconds.</p> <p>B. When the demand for hot water has been terminated, the display will return to the SET Temperature.</p> <p>C. When the water heater is turned off, the letters "OF" will be display.</p>	
6		FREEZE PROTECTION	This icon is displayed when the FREEZE PROTECTION MECHANISM is engaged.	

BUTTON DESCRIPTION

7		ON/OFF	Power Button. Switch from turning unit ON or turning unit OFF.	
8		SWITCH	Hold for 5 seconds to switch between degrees (°) Celcius or degrees (°) Fahrenheit	
9		UP	INCREASE SET Temperature by 1 degree increments. Setting range is 35°C/95°F to 50°C/122°F	
10		DOWN	DECREASE SET Temperature by 1 degree increments. Setting range is 35°C/95°F to 50°C/122°F	

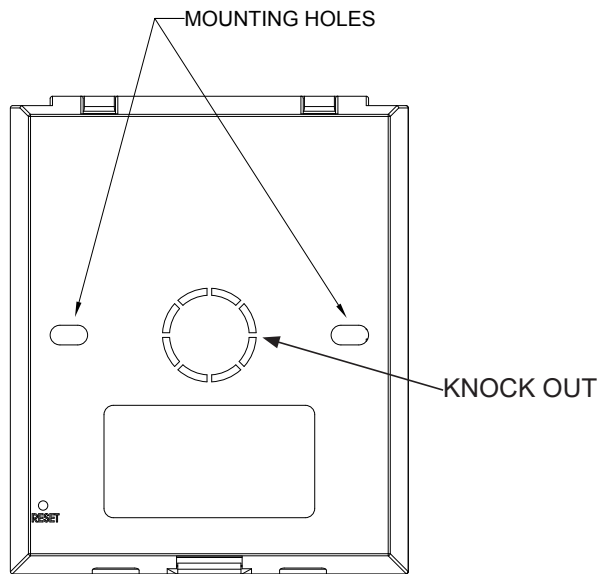
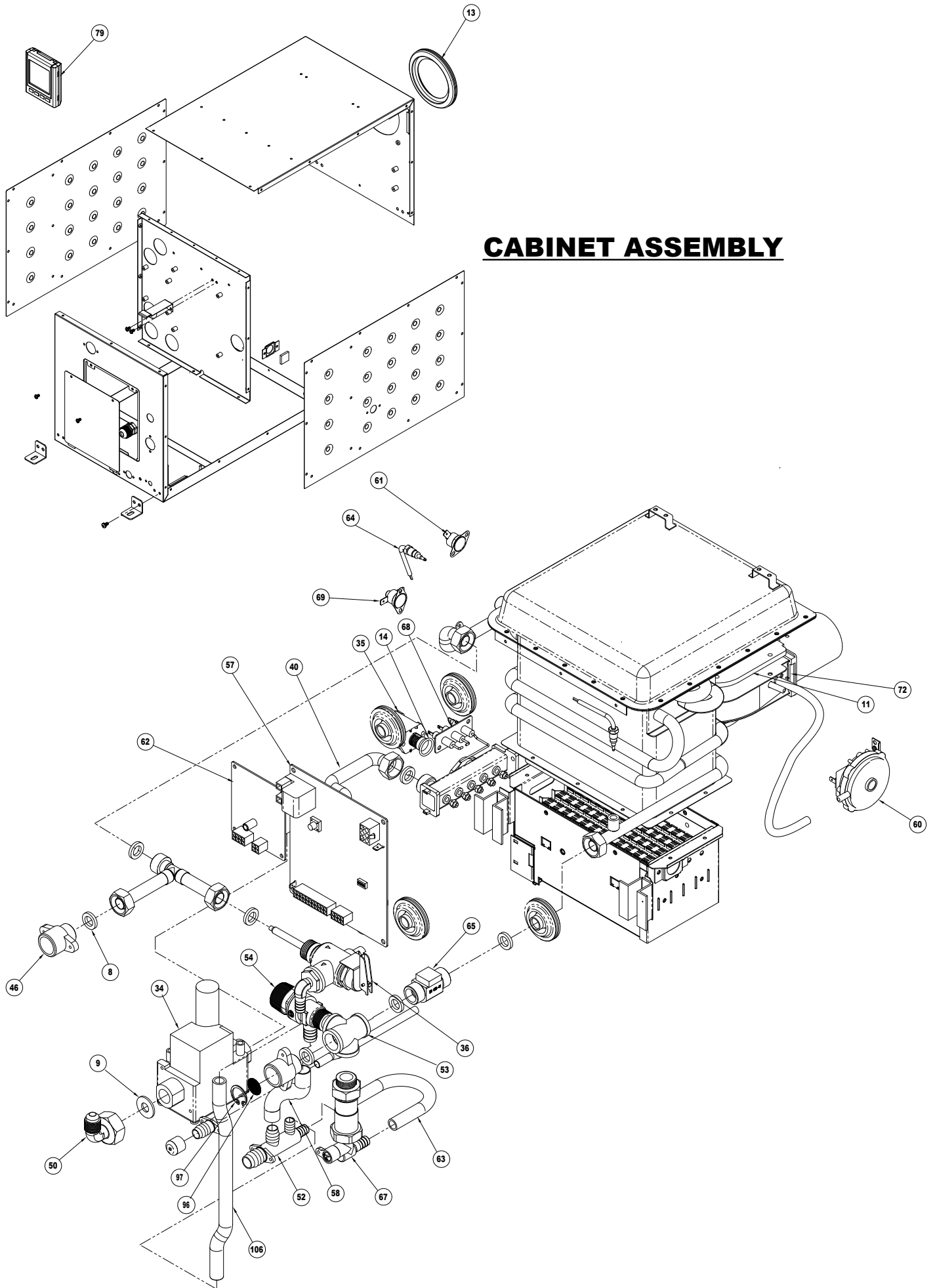

Figure 13



CABINET ASSEMBLY

NAUTILUS ON DEMAND WATER HEATER (IW60A) PARTS ILLUSTRATION AND PARTS LIST

ITEM NO.	PART NUMBER	DESCRIPTION	QTY.
8	071981	GASKET, RUBBER 1/2"	6
9	071982	GASKET, RUBBER 3/4"	3
11	071984	GASKET, BLOWER ASSEMBLY	1
13	071986	GASKET, EXHAUST CABINET	1
14	071991	GASKET, RUBBER SEALING RING	1
34	161248	VALVE, GAS DEMAND WH	1
35	161249	SOLENOID, TWO STAGE REGULATOR	1
36	161266	VALVE, PRESSURE RELIEF	1
40	172002	GAS INLET PIPE ON DEMAND WH	1
46	172044	FITTING, WATER ON DEMAND WH	2
50	172032	FITTING, GAS INLET	1
52	172095	DRAIN, 5/8 BRASS	1
53	172021	FITTING, INTER 4 WAY JOINT	1
54	172022	VALVE, WATER DRAIN SHUT-OFF	1
57	521135	MODULE BOARD IW60A	1
58	172026	TUBING, FLEXIBLE HOSE	1
60	233229	AIR PRESSURE SWITCH	1
61	233231	SENSOR, OVERHEAT	1
62	521136	MODULE BOARD, BLOWER CONTROLS	1
63	172025	TUBING, FROST PROTECTION DRAIN	1
64	233235	PROBE, TEMPERATURE ON DEMAND WH	2
65	233237	FLOW SENSOR ON DEMAND WH	1
67	233307	VALVE, FREEZE PROTECTION	1
68	233245	ELECTRODE/FLAME PROBE	1
69	233253	SWITCH, LIMIT WITH RESET	1
72	391127	EXHAUST ADAPTER, ON DEMAND WH	1
79A	161271	ON DEMAND CONTROL CENTER (WHITE)	A/R
79B	161272	ON DEMAND CONTROL CENTER (BLACK)	A/R
96	031382	SCREEN, WATER INLET	1
97	063849	CLIP, RETAINER	1
106	172098	TUBING, T&P DRAIN	1



RECREATIONAL VEHICLE WATER HEATER LIMITED WARRANTY

THIS IS A LIMITED 24 MONTH WARRANTY ONLY!!

This water heating product is warranted by Coast to Coast RV Services to the original purchaser to be free from defects in material and workmanship under normal use and maintenance for a period of 24 months from the date of purchase, regardless of the commencement date of use. It is the responsibility of the consumer/owner to establish the warranty period. Coast to Coast RV Services does not use warranty registration cards for its standard warranty. You are required to furnish proof of purchase date through a bill of sale or other payment record.

Coast to Coast RV Services will replace any parts that are found to be defective within the first 24 months and will pay a warranty service allowance directly to the authorized Coast to Coast RV Services approved Agent at rates mutually agreed upon between Coast to Coast RV Services and its authorized service center or agent. Water heater must be returned to a Coast to Coast RV Services authorized service center. Coast to Coast RV Services will not bear costs involving traveling time from their service agents.

Service agents can perform warranty repairs on site but all traveling time will be paid by owner of Vehicle or Caravan.

COAST TO COAST RV SERVICES WILL NOT BE RESPONSIBLE FOR:

1. Normal maintenance as outlined in the installation and operation instructions owner's manual including cleaning of the component parts and cleaning or replacement of the burner orifice. Any water damage arising directly or indirectly from any defect in the water heater or component parts or from its use.
2. Initial check outs and subsequent check outs which indicates the water heater is operating properly or diagnosis without repair.
3. Damage or repairs required as a consequence of faulty or incorrect installation or application not in conformance with installation instructions.
4. Failure to start or operate due to loose or disconnected wire, water or dirt in controls, fuel lines and gas tanks, improper gas pressure or low voltage.
5. Cleaning adjustment of components, electrode, burner tube, pilot and thermocouple.
6. Costs incurred in gaining access to the water heater.
7. Parts or accessories not supplied by Coast to Coast RV Services.
8. Freight charges incurred from parts replacement.
9. Damage or repairs as a consequence of any misapplication, abuse, unreasonable use, unauthorized alteration, improper service, improper operation or failure to provide reasonable and necessary maintenance.
10. Any products whose serial number has been altered, defaced or removed.
11. Damage as a result of floods, winds, lightning, accidents, corrosive atmosphere or other conditions beyond the control of Coast to Coast RV Services.
12. Any special indirect or consequential property, economic or commercial damage of any nature whatsoever.

Some states do not allow the exclusion of accidental or consequential damages, so the above limitation may not apply to you.

NO REPRESENTATIVE, DEALER OR OTHER PERSON IS AUTHORIZED TO ASSUME FOR COAST TO COAST RV SERVICES ANY ADDITIONAL, DIFFERENT OR OTHER LIABILITY IN CONNECTION WITH THE SALE OF THIS WATER HEATING PRODUCT.

For full warranty terms and conditions, please visit www.coastrv.com.au or www.coastrv.co.nz

This warranty gives you specific legal rights. You may also have additional rights which vary from state to state.

IF YOU HAVE A PRODUCT PROBLEM

First: If your RV has its original water heater and is still under the RV manufacturer's warranty. Follow the steps described in the RV owner's manual.

Second: Contact:
Coast to Coast RV Services
PO Box 6287 | Silverwater NSW 1811 Australia
Phone: (02) 9645 7600 | Fax: (02) 9645 7688
Email: warranty@coastrv.com.au



Coast RV Pty Ltd.
PO BOX 6287
SILVERWATER NSW 1811 Australia
www.coastrv.com.au