

# MYCOOLMAN

## Operation Manual

CCA3000/CCA-AD01  
RV Air Conditioner/Air Distribution Box







 LEISURE-TEC Australia Pty Ltd

Thanks for choosing Our RV air conditioning devices. Please read the instructions carefully before installation or first use of the device and store it in a place where all users can find it for easy reference. If the device is transferred or sold, please hand over the instructions along with it so that the new user is aware of installation methods, usage, and safety requirements.

## Table of content

1.0 Explanation of symbols .....	1
2.0 Safety instructions .....	1
2.1 General safety instructions .....	1
2.2 Operating the device safely .....	3
3.0 Intended use .....	3
4.0 Technical description .....	4
4.1 Components .....	4
4.2 Control panel .....	5
4.3 Remote control .....	5
4.4 Air conditioning modes .....	7
5.0 Installation instructions .....	8
5.1 Choosing Installation Loc .....	8
5.2 Roof preparation .....	11
5.3 Placing the rooftop air conditioner on the roof .....	13
5.4 Installing discharge duct and mounting bracket .....	16
5.5 Wiring the system .....	17
6.0 Initial use .....	22
6.1 Inspection before starting up .....	22
6.2 Checking remote control and insert batteries .....	22
7.0 Operating instructions .....	22
7.1 Operating control panel .....	22
7.2 Operating remote control .....	23
8.0 Cleaning and maintenance .....	25
9.0 Troubleshooting .....	26
10.0 Technical data .....	30
11.0 Wiring diagram .....	31
12.0 Parts list .....	32
13.0 Warranty .....	34

## 1.0 Explanation of symbols

- |   |  |
|---|--|
|  <b>DANGER!</b>    | Indicates a potentially hazardous situation which, if not avoided, could result in death or serious injury.  |
|  <b>WARNING!</b>   | Indicates a potentially hazardous situation which, if not avoided, could result in minor or moderate injury. |
|  <b>ATTENTION!</b> | Indicates a potentially hazardous situation which, if not avoided, could result in property damage.          |
|  <b>NOTE!</b>      | Supplementary information for product operation.   |

## 2.0 Safety instructions

Please observe the prescribed safety instructions and stipulations from the vehicle manufacturer and service workshops.

**Mycoolman** accepts no liability for damage in the following cases:

- Faulty assembly or connection
- Damage to the product resulting from mechanical influences and excess voltage
- Alterations to the product without express permission from the manufacturer.
- Use for purposes other than those described in the operating manual.

### 2.1 General safety instructions

#### **WARNING!**

- Installation and repair of the rooftop air conditioner may only be carried out by qualified personnel who are familiar with the risks involved and the relevant regulations. Inadequate repairs may cause serious hazards.
- This appliance can be used by children aged 8 years and above and persons with reduced physical, sensory or mental capabilities or lack of experience and knowledge if they have been given supervision or instruction concerning the use of the appliance in a safe way and understand the hazards involved.
- Children shall not play with the appliance. Cleaning and user maintenance shall not be made by children without supervision.

- Keep electrical devices out of reach of children or infirm persons. Do not allow them to use electrical devices without supervision.  
Persons whose physical, sensory or mental capabilities or whose lack of experience and knowledge prevent them from using electrical devices safely should not use it without supervision or instruction by a responsible person.  
Do not undo the upper cover of the rooftop air conditioner in the event of a fire. Use approved extinguishing agents instead. Do not use water to extinguish fires.

## **ATTENTION!**

- The rooftop air conditioner must be installed securely so that it cannot fall down.
- Do not use the rooftop air conditioner near flammable fluids or in closed rooms.
- Make sure no combustible objects are stored or installed near the air outlet. A distance of at least 50 cm must be kept.
- Do not reach into air outlets or insert any foreign objects in the rooftop air conditioner.

## **ATTENTION!**

- Only use the device as intended.
- The rooftop air conditioner is not suitable for use in agricultural or construction vehicles.
- Do not make any alterations or conversions to the electrical device.
- If faults occur in the refrigerant circuit, the system must be checked by a specialist company and repaired properly. The refrigerant must never be released into the air.

## **NOTE!**

Please ask your vehicle manufacturer if a technical inspection is required after fitting an rooftop air conditioner and whether the height entered in the vehicle documents needs to be altered.

## 2.2 Operating the device safely

### **WARNING!**

- The electrical power supply may only be connected by a qualified electrician.
- Always disconnect the power supply when working on the electrical device.

### **ATTENTION!**

- Use cable ducts to lay cables through walls with sharp edges.
- Do not lay loose or bent cables next to electrically conductive materials (metal).
- Operate the electrical device only if you are certain that the housing and the cables are undamaged.

## 3.0 Intended use

The rooftop air conditioner is designed for use in motorcaravans, caravans and other vehicles with habitation compartments only.

The rooftop air conditioner is not suitable for installation in construction machines, agricultural machines or similar equipment. It will not work properly if exposed to strong vibrations.

Please do not use the rooftop air conditioner if the ambient temperature is over 52° C. The performance will be affected at extreme temperature.

### **NOTE!**

You can find additional information on rooftop air conditioners in the operating manual, such as the technical description or the controls.

## 4.0 Technical description

The rooftop air conditioner supplies the interior with cool or warm dehumidified air without dust and dirt.

The rooftop air conditioner is operated with the button on control panel and the remote control.

### **NOTE!**

- The rooftop air conditioner can lower the temperature within the vehicle to a certain level. The temperature depends on the type of vehicle, the ambient temperature, and the cooling capacity of your rooftop air conditioner.
- Below an outer temperature of 16° C the rooftop air conditioner does not cool anymore. In this case only use the "Ventilation" mode.

## 4.1 Components

The refrigerant circuit of the rooftop air conditioner consists of the following main components (see Parts list in page 29).

### • **Compressor**

The compressor draws in the refrigerant used and compresses it. This raises the pressure and therefore the temperature of the refrigerant.

### • **Condenser**

The built-in liquefier works like a cooler or heat exchanger. The air flowing past absorbs the heat and the hot refrigerant gas cools down and becomes liquid.

### • **Evaporator**

The evaporators cool down and dehumidify the air flowing past them. The refrigerant absorbs the heat and vaporizes.



### • **Blower**

The blower distributes the cooled air within the vehicle through an air outlet unit.

## 4.2 Control panel

The control panel is at the air outlet unit of the rooftop air conditioner. It contains the following control and display elements:



Explanation	
Button 	Switch the rooftop air conditioner on, and long press for 3 seconds to power off.
Button 	Adjusting the fan speed.
Button <b>M</b>	Selecting the operation mode.
Button <b>+</b> <b>-</b>	Increasing/reducing the temperature value.

## 4.3 Remote control

All settings of the device are transmitted to the rooftop air conditioner by remote control.



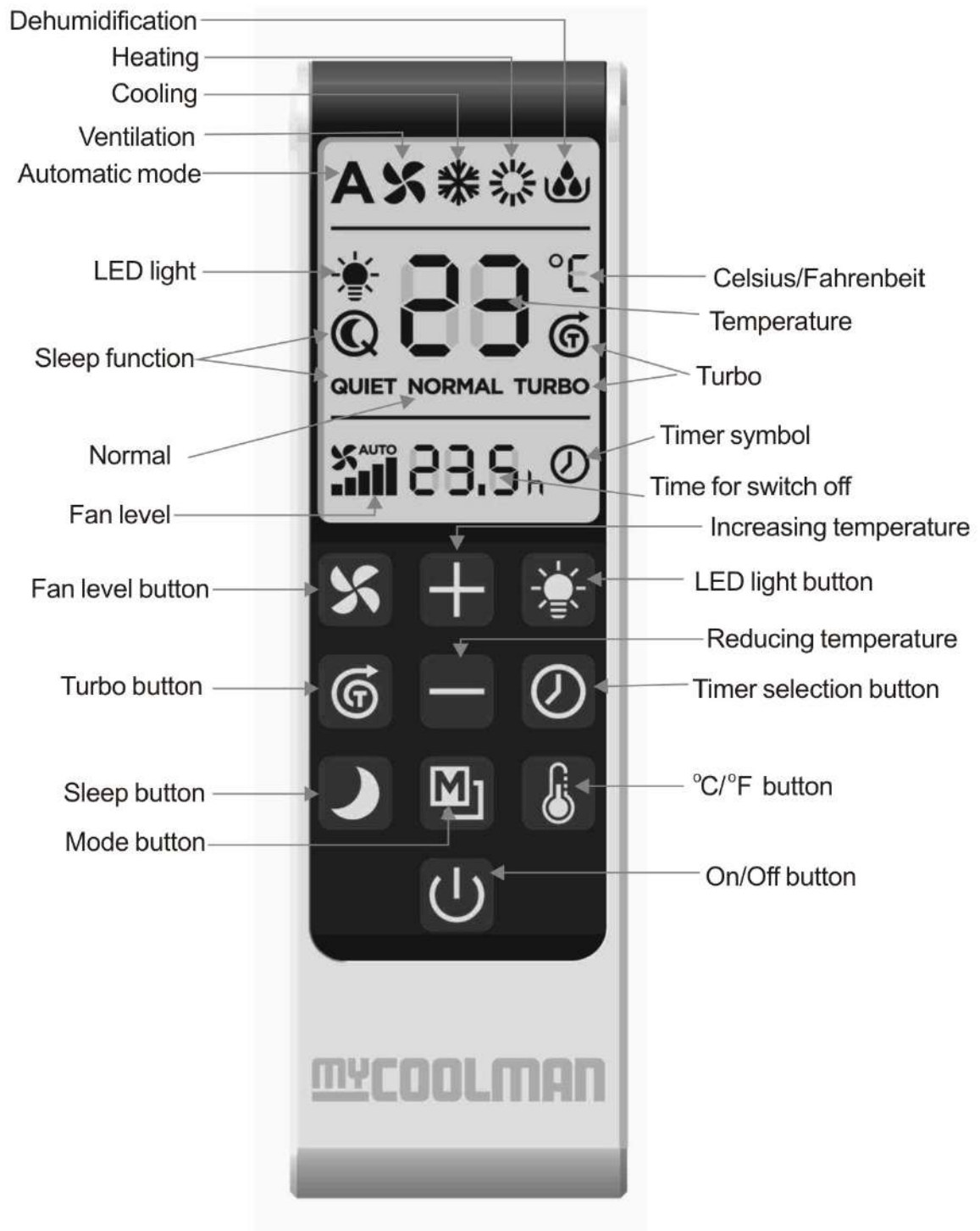

The following control and display elements are available on the remote control:

# MYCOOLMAN



## 4.4 Air conditioning modes

The rooftop air conditioner has the following air conditioning modes:

Mode	Display message	Explanation
Automatic	<b>A</b>	The rooftop air conditioner will automatically maintain the set temperature by heating or cooling as needed.
Cooling		Setting the temperature and fan level, the rooftop air conditioner will reduce the indoor temperature to the value.
Dehumidification		The temperature and fan speed will be locked to 23°C /73 °F and Fan level 3, not adjustable.
Heating		Setting the temperature and fan level, the rooftop air conditioner will increase the indoor temperature to the value.
Ventilation		Setting the fan level, the rooftop air conditioner will blow air into the indoor.

### **i** NOTE!

Please use the connecting wirings which are in accordance with state regulations. When selecting the generator capacity, it is important to consider the total power consumption of the vehicle, and the power loss of the generator due to high altitude and lack of maintenance.  
Circuit protection: Make sure to use the leakage protector.

## 5.0 Installation instructions

### ATTENTION!

- Read installation and operating instructions carefully before attempting to start your rooftop air conditioner installation.
- The manufacturer will not be liable for any damages or injury incurred due to non-compliance of the instructions.
- Installation must comply with the national and local codes and/or regulations. DO NOT add any devices or accessories to the rooftop air conditioner except those specifically authorized in writing by Manufacturer.
- This equipment must be serviced by qualified personnel and some states require these people to be licensed.

### 5.1 Choosing Installation location

This rooftop air conditioner is specifically designed for installation on the roof of a vehicle with habitation compartments. The following points need to be considered to determine the cooling requirements:

- The size of the vehicle.
- The size of the window (increases heat gain).
- Amount of insulation in walls and roof.
- Geographical location where the vehicle will be used.
- **Normal locations:** the rooftop air conditioner is designed to fit over an existing roof vent opening. When the vent is removed, it normally creates a 360\*360mm (+/-2mm) opening or a 400\*400mm (+/-2mm) opening.
- **Other locations:** When no roof vent is available or another location is desired, the following is recommended:
  - a. **For one unit installation:** The rooftop air conditioner should be mounted slightly forward of center (front to back) and centered from side to side. See FIG.01.

01

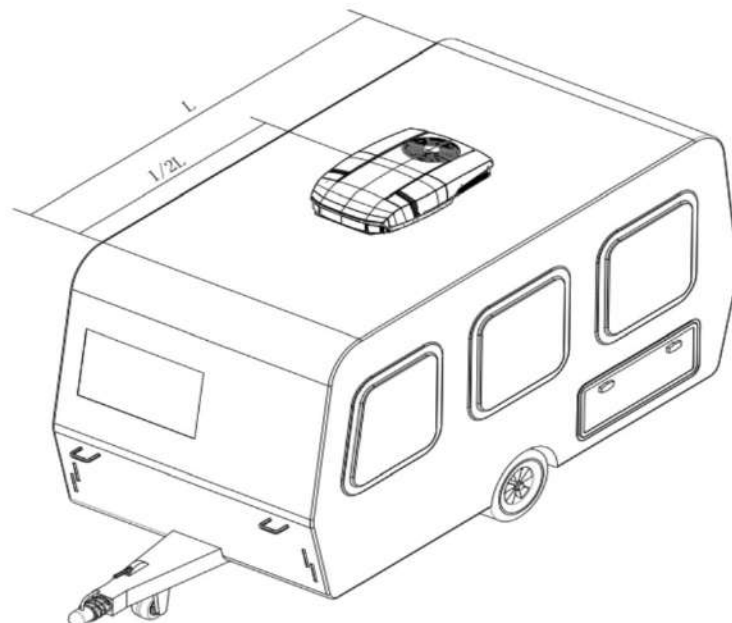

- b. **For two units installation:** Install one rooftop air conditioner 1/3 and the other 2/3 from front of vehicle and centered from side to side. See FIG.02.

02

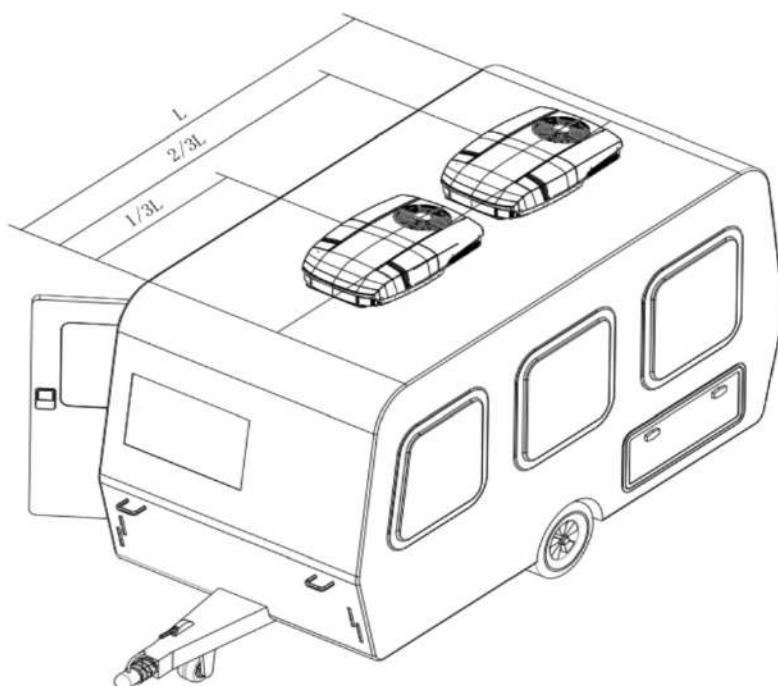

- **After location has been selected:**

- Check for obstructions in the area where rooftop air conditioner will be installed.
- The roof must be designed to support 60KG when the vehicle is in motion.  
Normally a 100KG static load design will meet this requirement.
- Check inside the vehicle for air distribution box obstructions (i.e. door openings, room dividers, curtains, ceiling fixtures, etc.). Please check the dimensions of the rooftop air conditioner and the air distribution box. See FIG.03.

**⚠ ATTENTION!**

- It is preferred that the unit be installed on a relatively flat and level roof section measured with the vehicle parked on a level surface, but up to a 5° tilt is acceptable.
- It is the responsibility of the designer to ensure the structural integrity of the vehicle. Never create a low spot on the roof where water will collect. Water standing around the rooftop air conditioner may leak into the interior causing damage to the product and vehicle.

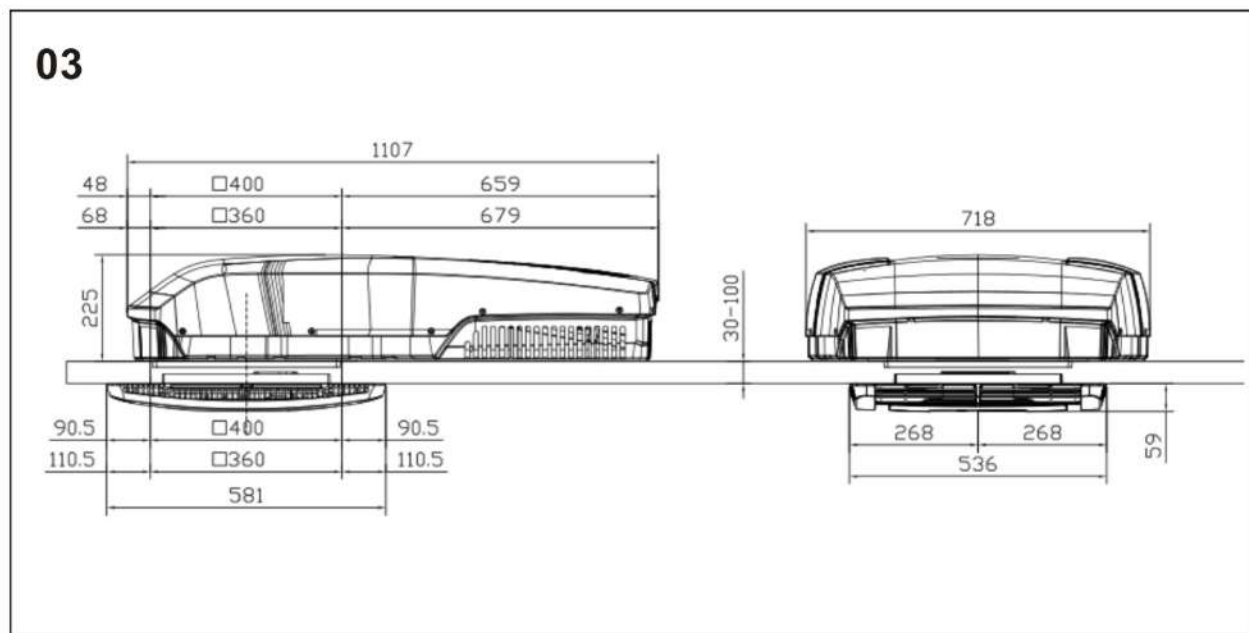

## 5.2 Roof preparation

- Roof vent removal:
  - a. Unscrew and remove the roof vent.
  - b. Remove all caulking compound around opening.
  - c. Seal all screw holes and seams where the roof gasket will be located. Use a good grade of all weather sealer.
- New opening : (installation other than vent opening)  
A 360\*360mm (+/-2mm) or 400\*400mm (+/-2mm) opening must be cut through the roof and ceiling of the vehicle if the existing vents will not be used. It is recommended this opening be located between roof reinforcing members.

Mark a 360\*360mm (+/-2mm) or 400\*400mm (+/-2mm) square on the roof and carefully cut the opening. Using the roof opening as a guide, cut the matching hole in the ceiling. See FIG.04.

### DANGER!

- There may be electrical wiring between the roof and the ceiling. Disconnect 220V AC power cord and the positive (+) 12V DC terminal at the supply battery. Failure to follow this instruction may create a shock hazard causing death or severe personal injury.
- Opening instructions:
  - a. If the opening exceeds 365\*365mm, it will be necessary to install spacers.
  - b. If the opening is less than 358\*358mm, it must be enlarged.
- Wiring requirements:  
Route a copper 2.5mm<sup>2</sup>, with ground, supply line from the fuse or circuit breaker box to the roof opening.
  - a. The power supply must be on a separate 20 Amp Time Delay Fuse or HACR Circuit Breaker.
  - b. Make sure at least 380mm of wire extends into the roof opening. This insures easy

- rooftop air conditioner attachment.
- c. Wiring methods must comply with all national and local wiring codes and/or regulations.
  - d. If vent fan was removed, the existing wire may be used provided it is of proper size and correctly fused.
  - e. The entry wires to the opening need more protection to avoid damage.

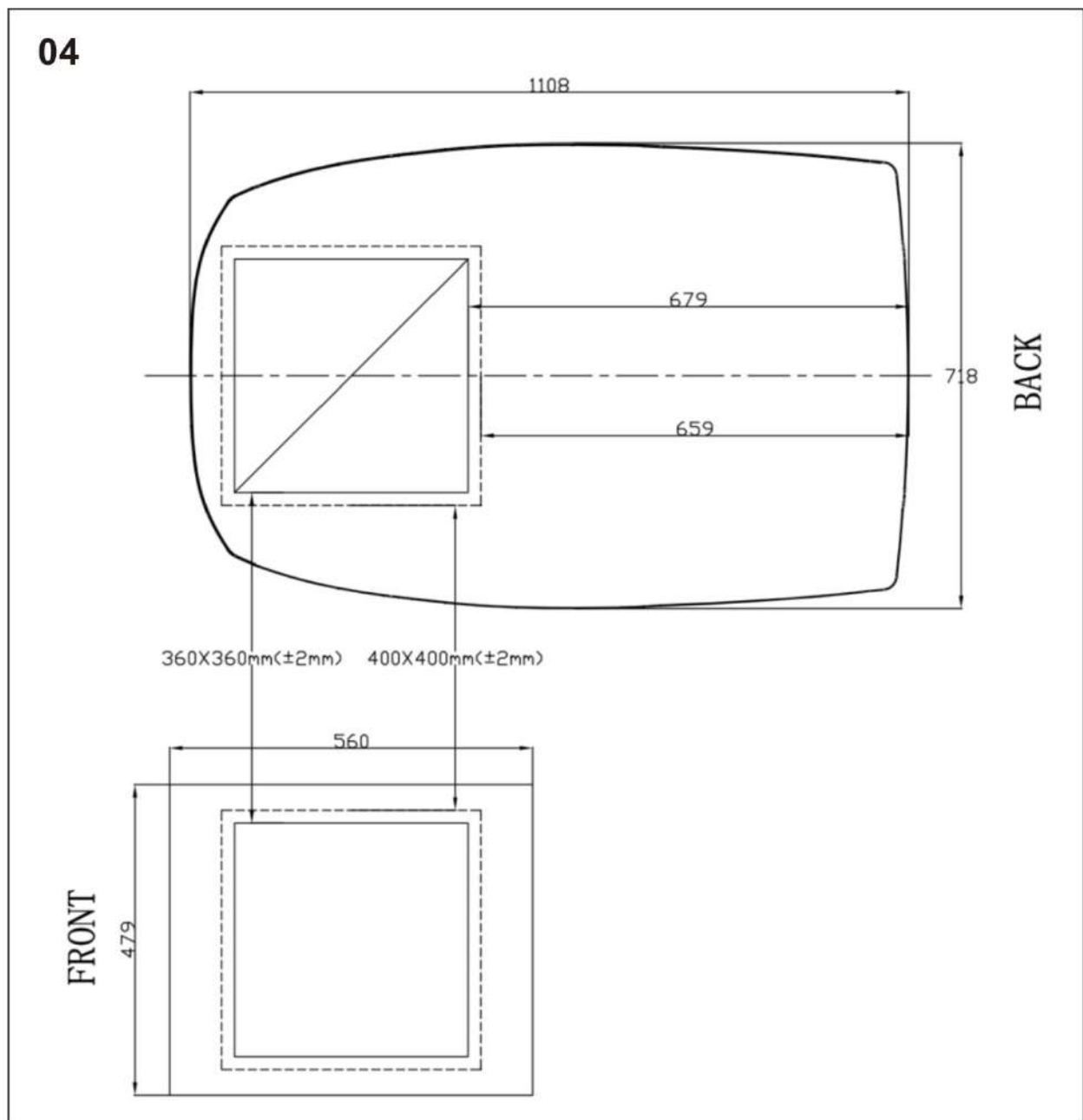

- The opening must be framed to provide adequate support and prevent air from being drawn from the roof cavity. Framing stock 20mm or more in thickness must be used. Remember to provide an entrance hole for the power supply wire. See FIG.05.

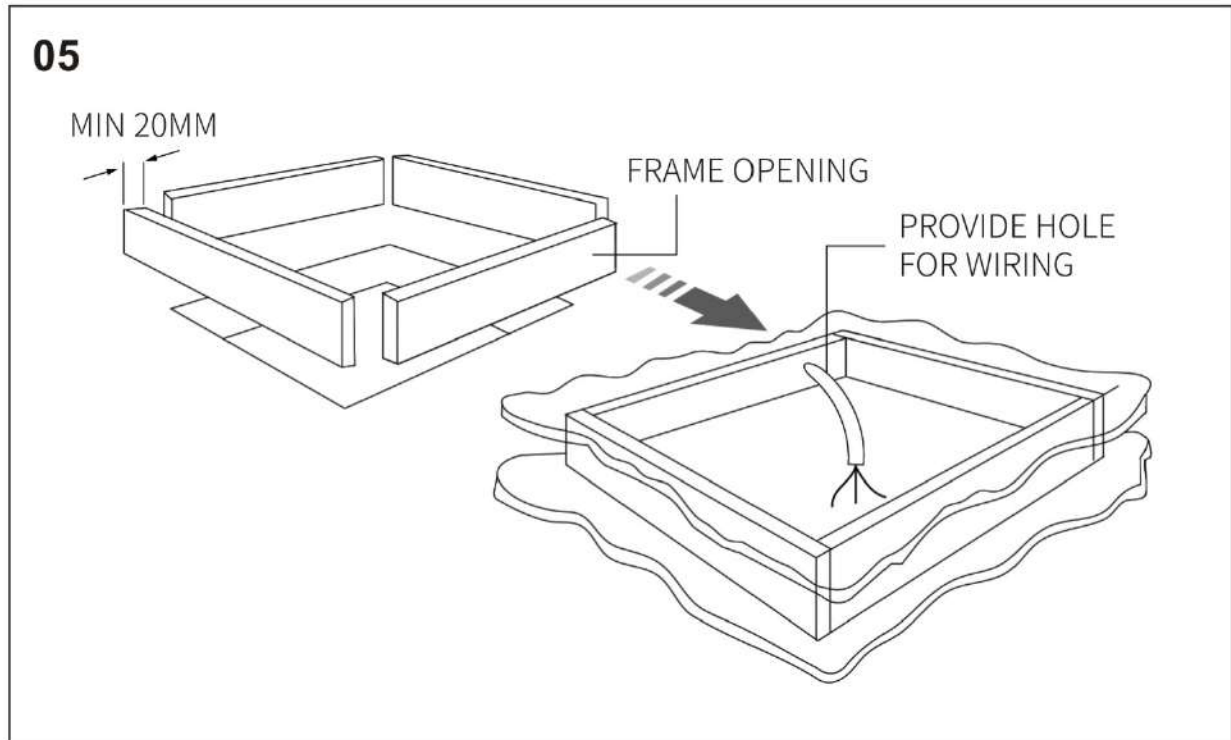

- The 360\*360mm (+/-2mm) or 400\*400mm (+/-2mm) roof opening is part of the return air duct and must be polished according to the industry standard.

### 5.3 Placing rooftop air conditioner on the roof

#### **ATTENTION!**

- This rooftop air conditioner weighs approximately 37Kg. To prevent back injury, use a mechanical hoist to place air conditioner on roof.
- Take out the roof mounting frame from the carton, and place it on the prepared opening in the roof, pay attention to the direction of the frame. There are two type of mounting frame offered in the package, one is for opening size of 360x360mm and the other one is for 400x400mm. See FIG.06.

06

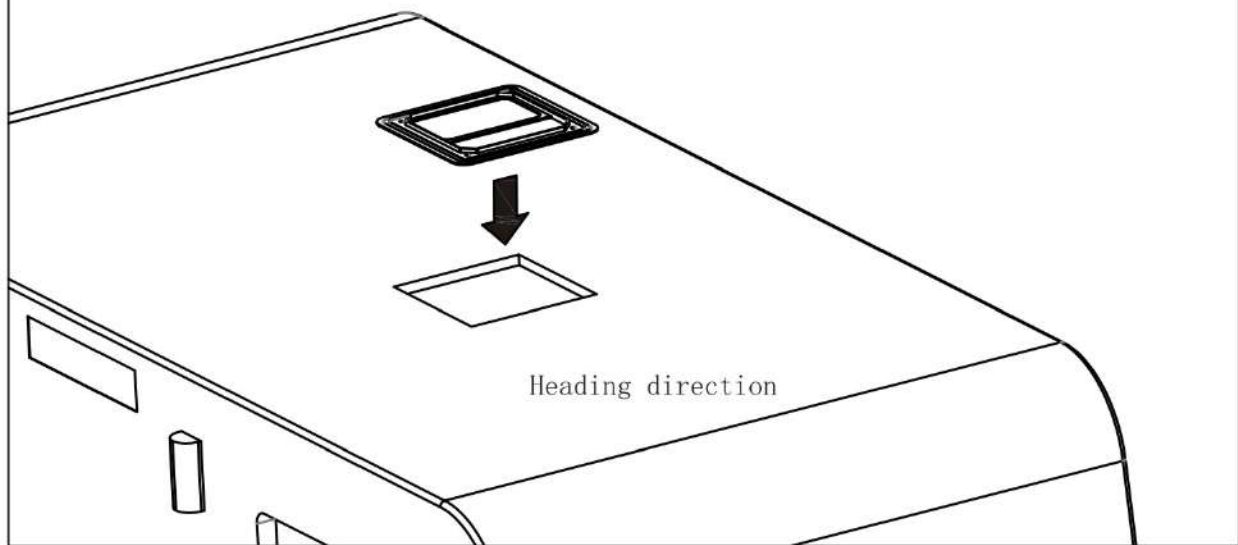

## **ATTENTION!**

- Do not slide the unit. This may damage the EVA gasket attached to the bottom and create a leaky installation.
- Seal around the roof mounting frame with flexible non-hardening butyl sealing compound. See FIG.07.

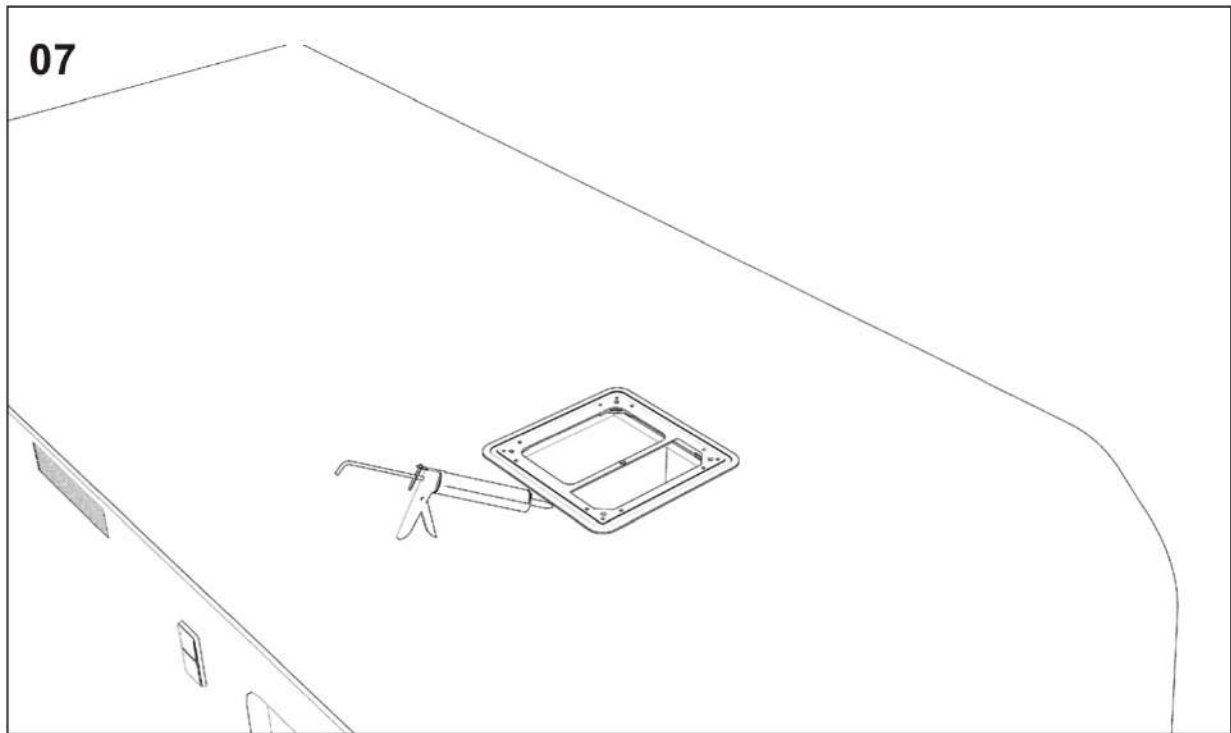

- Take out the rooftop air conditioner from the carton, and place it on the roof aligning with the roof mounting frame. See FIG.8.

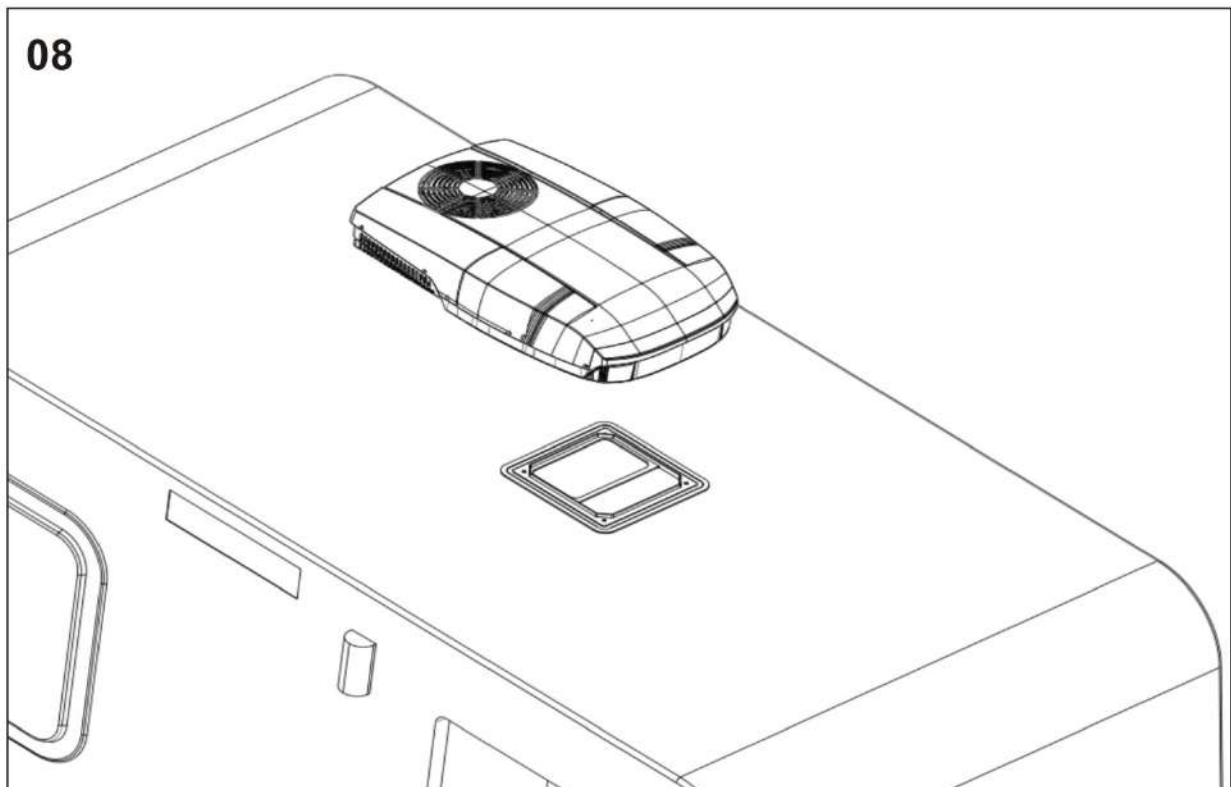

The condenser coil goes toward the rear of the vehicle. See FIG.9.

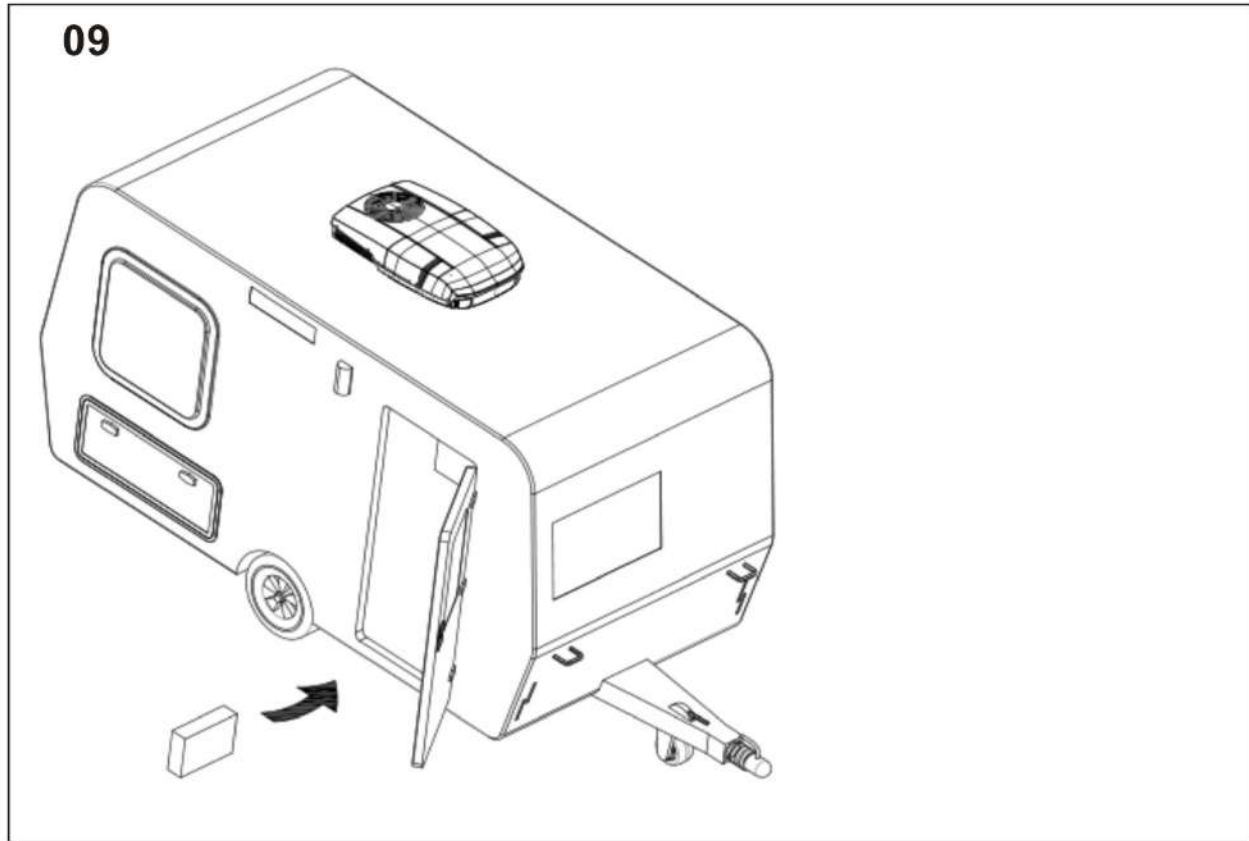

## 5.4 Wiring the system

### **⚠ DANGER!**

- Disconnect 220-240V AC. Failure to follow these instructions could create a shock hazard causing death or severe personal injury!
- This product is equipped with a 3 wires (grounded) system for protection against shock hazard. Make sure that the appliance is wired into a properly grounded 220-240V, 50/60Hz AC circuit and the polarity is correct. Failure to do so could result in death, personal injury or damage to the equipment.
- Take the wiring from the return air outlet and connect it to the connector, and then connect it with the prepared 220-240V power supply at the roof opening.
- Take out the communication cable and leave it there for next step connection later. See FIG.10.

10

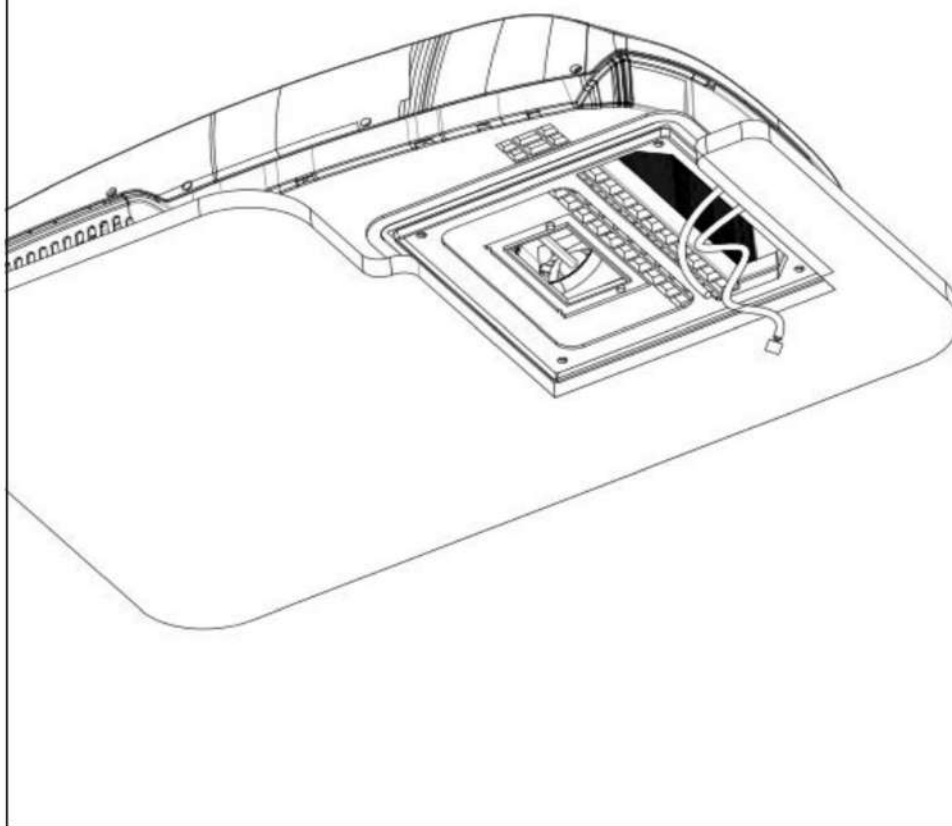

**Note:** All wiring must be done by qualified personnel and comply with the national and local wiring codes and/or regulations.

## 5.5 Installing discharge duct and mounting bracket

- Take out air diffuser, roof mounting bracket, air duct blocks and fasteners from the carton.
- Fasten the roof mounting bracket, roof mounting frame and rooftop air conditioner together with 4 long bolts M6 x 120mm, and the tightening torque is  $2.5\text{Nm} \pm 0.3\text{Nm}$ . See FIG.11.

11

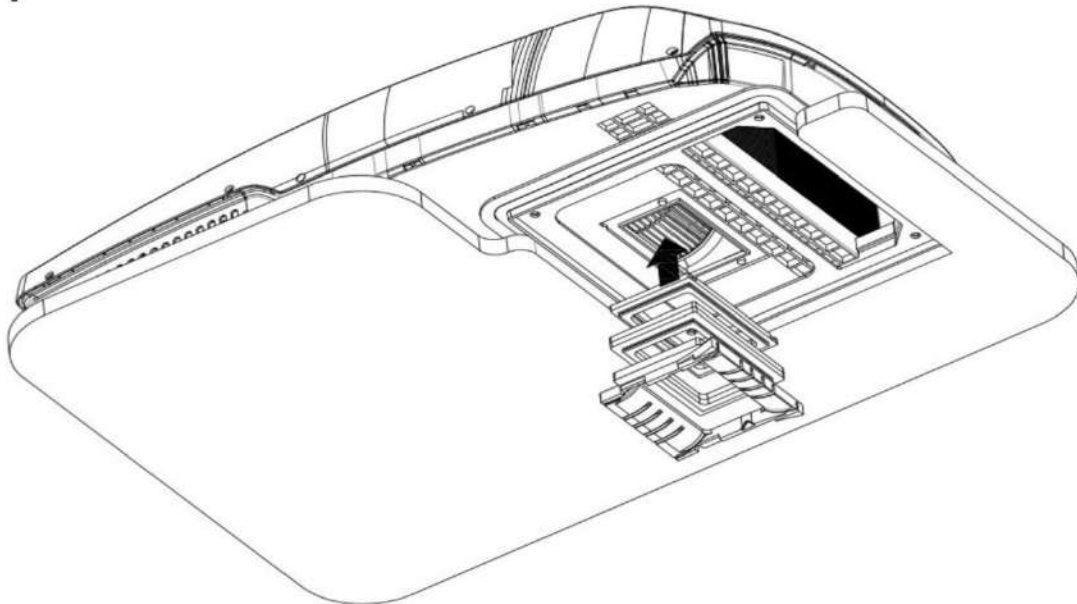

- According to the thickness of the roof, determine how many air duct blocks to use, and then install the blocks to the air outlet on base pan of rooftop air conditioner. See FIG.12.

12

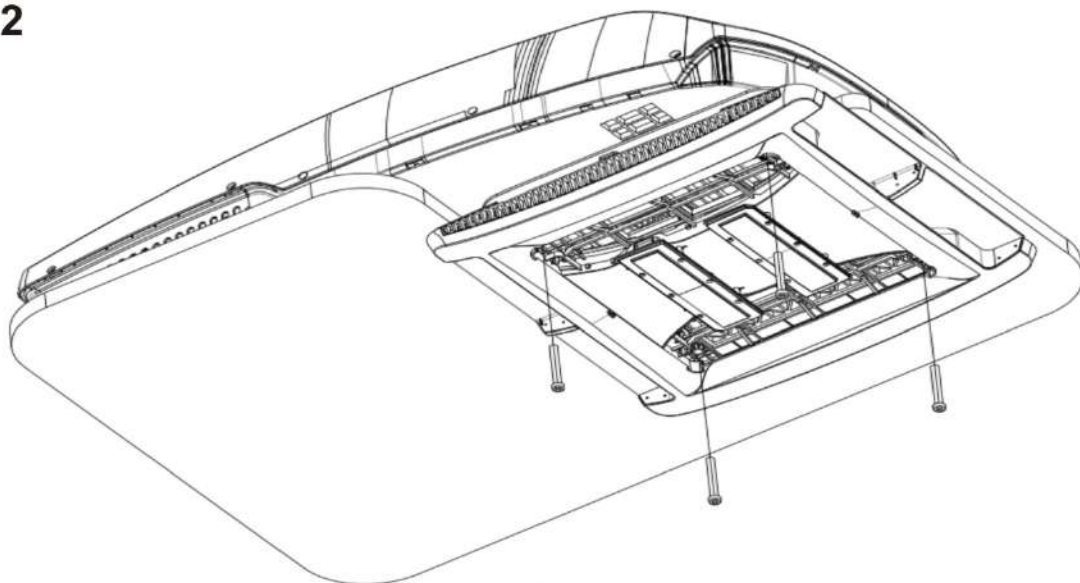

$2.5 \pm 0.3\text{Nm}$

Fig a. demonstrates the correct way to safely remove the air diffuser front cover. To unlock the latches behind the front cover, position your hands as shown in Fig a., and apply pressure with both thumbs. While maintaining the pressure with your thumbs, pull down the front cover vertically. If you feel any resistance, avoid forcefully pulling down the front cover. Instead, apply more pressure with your thumbs while pulling the front cover off to avoid damaging the locking mechanism.

**Fig a.**

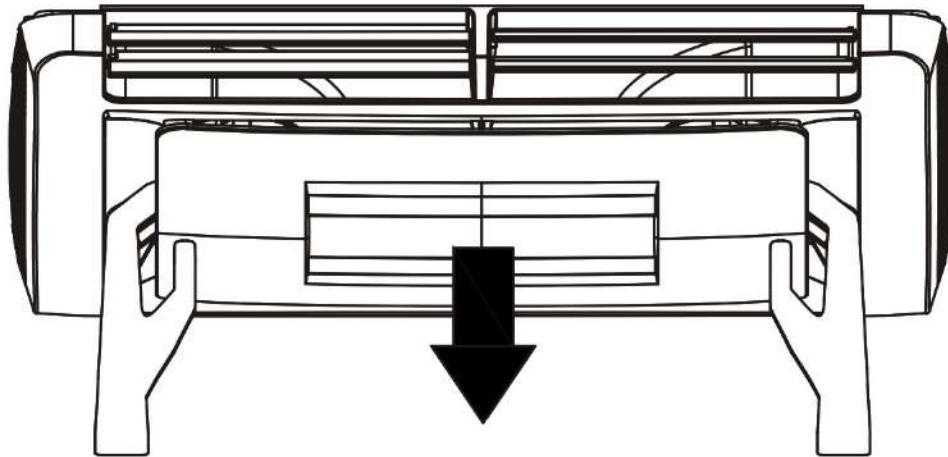

When push back the control panel cover to the air diffuser, the four latches on the cover must insert to four sockets on the air diffuser, show as on Fig b.

**Fig b.**

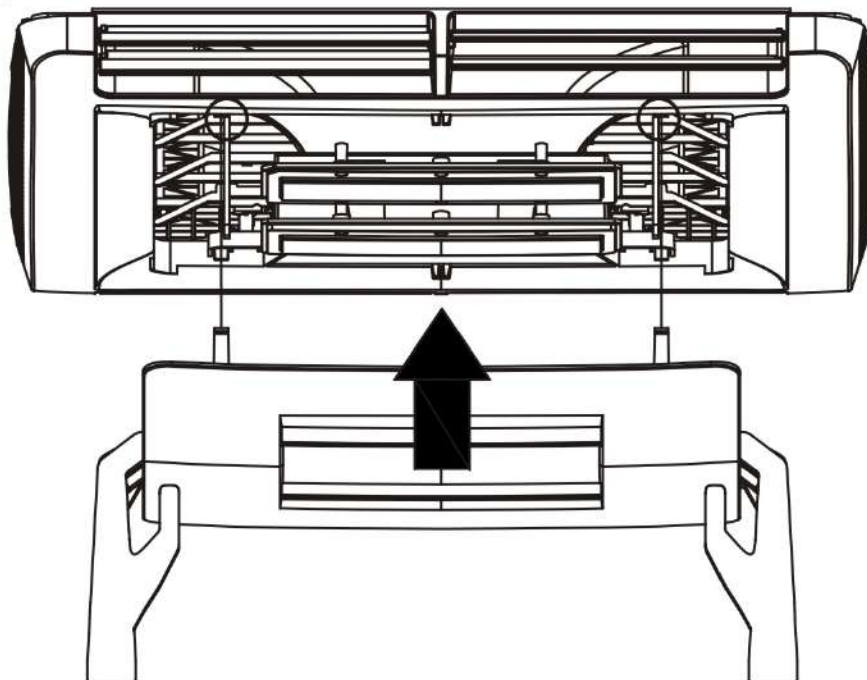

- Pull out the air filter and take out the communication cable from the air diffuser, connect it with the cable from the rooftop air conditioner.
- Install the air diffuser to roof mounting bracket with 4 nuts M6, then push the screw hole covers into the slots. See FIG.13.

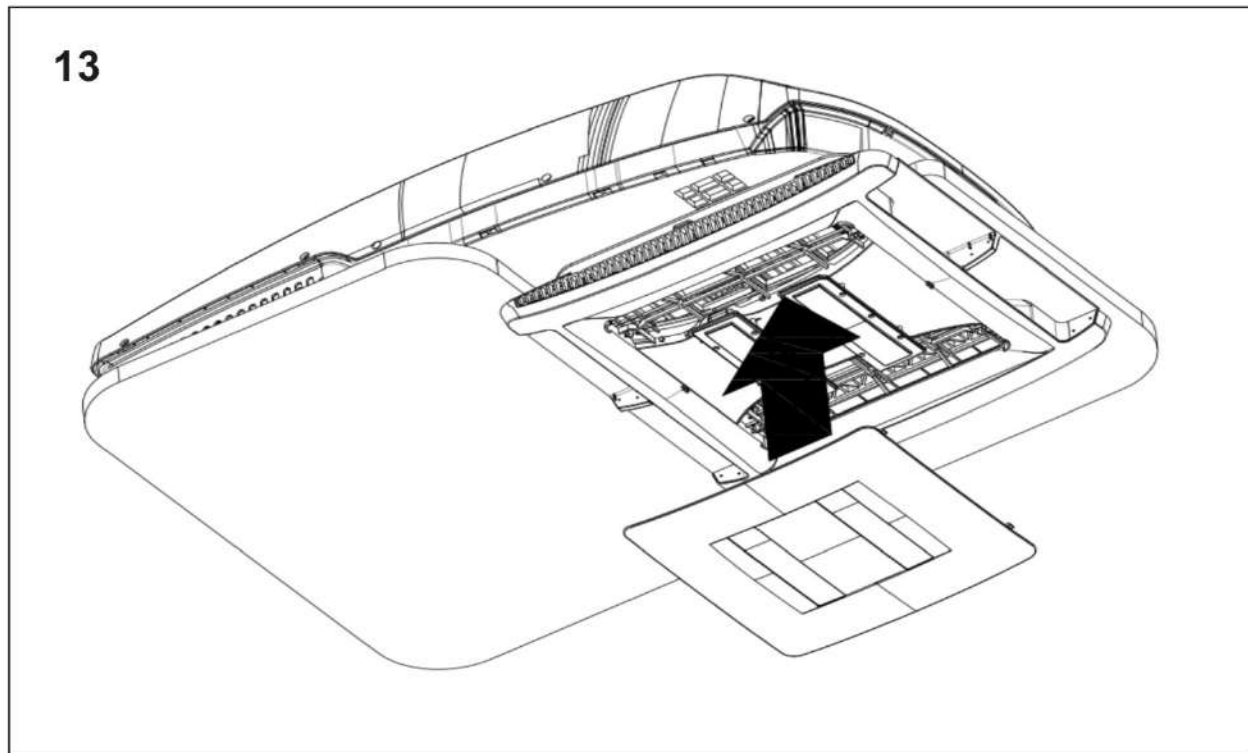

- If needed, the air diffuser can be fixed to the ceiling with 4 screws. Then push air filters into the correct place of air diffuser. See FIG.14.

**i NOTE!**

Check the thickness of the vehicle roof, the air duct is made of EPP material, which is divided into three parts: the bottom block, middle blocks and top block. The thickness of each middle block is 10mm, which is suitable for maximum 100mm roof thickness. Add or subtract the blocks as needed.

14

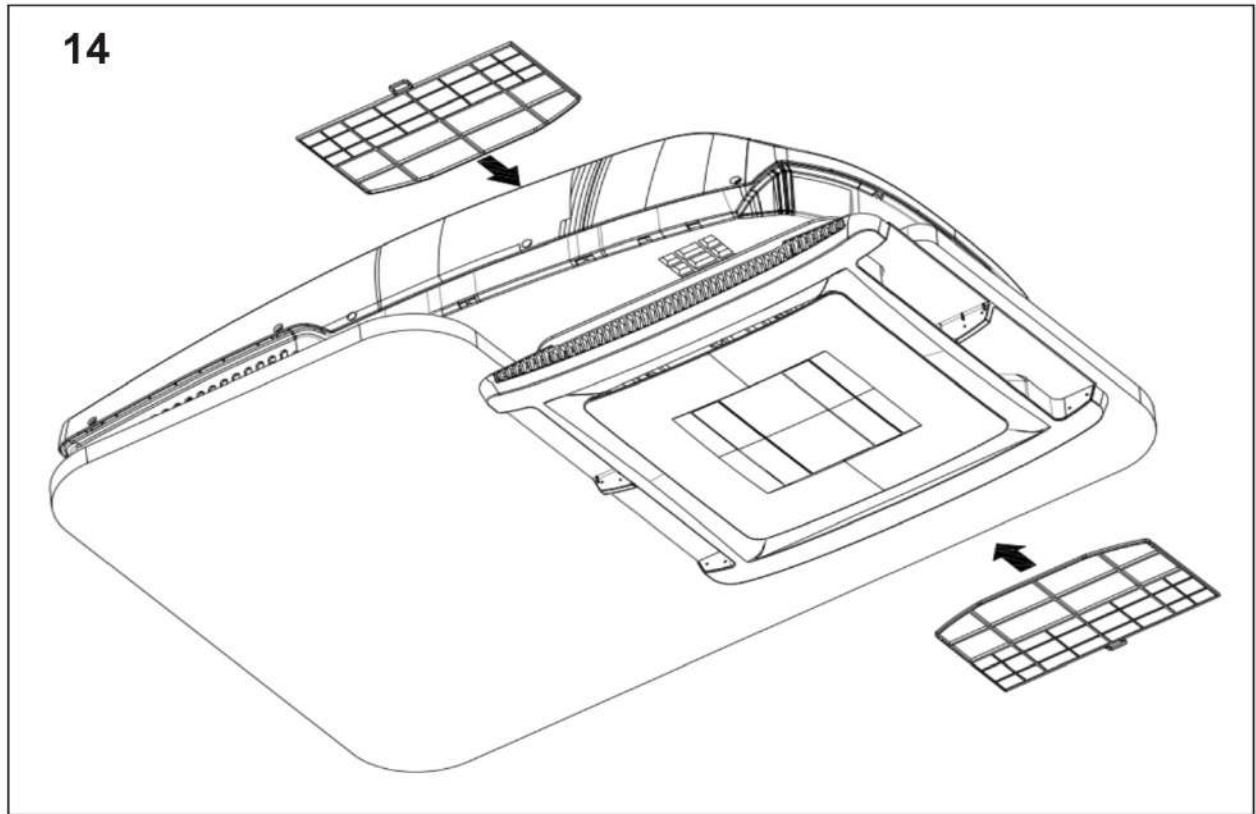

15

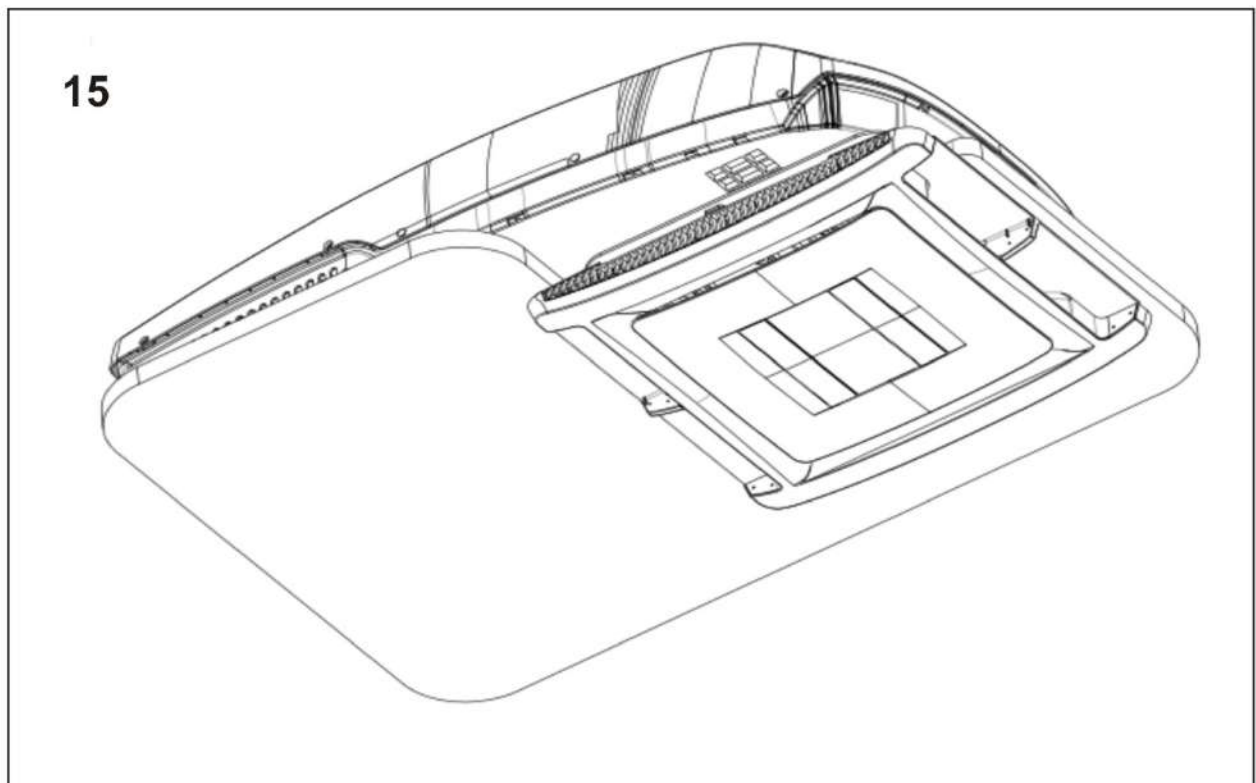

## 6.0 Initial use

### 6.1 Inspection before starting up

Before you switch on the rooftop air conditioner, observe the following:

- Check whether the supply voltage corresponds to the values specified in the data plate .
- Ensure both the air intake opening and the air nozzles are free. All ventilation grilles must always be kept free to ensure that the rooftop air conditioner is able to operate at maximum capacity.



#### **ATTENTION!**

- Do not insert your fingers or objects into the air nozzles or the intake grille.  
Beware of injury!

### 6.2 Checking remote control and insert batteries





The battery compartment is located on the lower back of the remote control.

- Gently push down the sliding lid out of the guide slot and remove it.
- Insert the new batteries (2 x type AAA) in the remote control as indicated in the battery compartment.
- Push the sliding lid into the guide slot, and push up to close it.

## 7.0 Operating the rooftop air conditioner

### 7.1 Basic notes on operation

The following operations can be achieved by touching the control panel.















Operating mode	Features
On/ Off	Press  to switch on the rooftop air, press and hold it for 3 seconds to switch it off.
Mode selection	Press  to select five operating modes in order, Automatic, Cooling, Dehumidification, Ventilation and Heating.
Fan speed adjusting	Press  one time, the fan speed will increase one level, and comes Auto after level 4.
Temperature adjusting	To set up the temperature by pressing  or  .

In addition to the above operations, the remote control can also perform the following operations:

- Sleep function
- Turbo function
- LED light
- Timer function
- Celsius/Fahrenheit conversion

## 7.2 Operating instructions of remote control

- The remote control lights up the display screen 2 seconds after the batteries are installed, and enters the standby state after displaying 16°C for 6 seconds.
- In the OFF state, exception the LED light and the power button, other buttons do not work, and the screen backlight will go out after 6 seconds.
- In the ON state, press the corresponding button to transmit the signal. Please note that the remote control needs to face the infrared receiver on the air diffuser.

Button	
On/Off	Press  , to power on or off the rooftop air conditioner.
Mode selection	Press  , to select five operating modes in order, Automatic, Cooling, Dehumidification, Ventilation and Heating.
Fan speed adjusting	Press  one time, the fan speed will increase one level, and comes Auto after level 4.
Sleep function	Press  , the compressor and fan will run at low speed. The initial temperature setting is 26 °C. You can adjust the temperature setting with  or  . The fan speed is locked at level 1 and can't be adjusted. Press  again and return to normal mode.
Turbo function	Press  , the compressor and fan will run at the maximum speed, the temperature can be set by pressing  or  . The fan speed is locked at level 4 and can't be adjusted. Press  again and return to normal mode.
LED light	Press  , to switch on or off the LED light on air diffuser.
Timer function	Press  , to set the Switch-Off time of the rooftop air conditioner. Each time you press it, the time will increase by 0.5 hours, and the maximum setting is 12 hours.
Celsius/Fahrenheit conversion	Press  to display Celsius or Fahrenheit.

## 8.0 Cleaning and maintenance

### **WARNING!**

- Any other maintenance work to that which is described here may only be carried out by qualified personnel who are familiar with the risks involved when handling refrigerant and air conditioning systems as well as the relevant regulations.

### **ATTENTION! Beware of damage**

- Do not clean the rooftop air conditioner with a high-pressure cleaner. Exposure to water can damage the rooftop air conditioner.
- Do not use sharp or hard objects or cleaning agents for cleaning as these may damage the rooftop air conditioner.
- To clean the rooftop air conditioner, use water with a gentle cleaning agent. Never use petrol, diesel or solvents.

### **Cleaning the rooftop air conditioner**

- Clean the housing of the rooftop air conditioner and the air outlet unit occasionally with a damp cloth.
- Regularly remove leaves and other dirt from the ventilation grilles of the rooftop air conditioner. Make sure you do not damage the grilles in the process.
- Regularly clean the air filters on both side of air diffuser with warm water, and reinstall them after drying.
- Clean the remote control with a slightly damp cloth from time to time. We recommend using a cleaning cloth for glasses to clean the display.

### **Maintenance of the rooftop air conditioner**

- Regularly check whether the condensation water drainage channels at the sides of the rooftop air conditioner are clear and the condensation water is able to escape.
- Check the seal between the rooftop air conditioner and the roof of the vehicle for cracks and other damage once per year.

## 9.0 Troubleshooting

If the rooftop air conditioner fails, the fault light on the upper right corner of the display will light up and the Error code will be displayed.

No	Fault Code	Fault	Cause	Remedy
1	E1	Exhaust temperature sensor failure	Sensor is in open circuit or short circuit or controller circuit board failure.	Check the temperature sensor located in the rooftop unit compressor discharge high pressure pipe whether it's disconnected or resistance value is around 50K $\Omega$ [at 25 $^{\circ}$ C], if both are negative, replace the compressor controller board.
2	E2	Indoor fan failure	Indoor fan has no signal for 20s continuously and error code appears.	Check the terminal voltage(DC) of GND (the black wire) and VSP (the yellow wire) at the controller. If the voltage is 2-7V, it outputted with control signal. If the voltage is below 2V or above 7V, the controller is damaged. Detect the terminal voltage of HV (the red wire) and GND (the black wire), and the normal output voltage is 310V. If it is detected without power, the controller is damaged. If the voltage shows in normal with both lines, the fan motor is damaged.
3	E3	Outdoor fan failure	Outdoor fan has no signal for 20s continuously and error code appears.	Check the terminal voltage(DC) of GND (the black wire) and VSP (the yellow wire) at the controller. If the voltage is 2-7V, it outputted with control signal. If the voltage is below 2V or above 7V, the controller is damaged. Detect the terminal voltage of HV (the red wire) and GND (the black wire), and the normal output voltage is 310V. If it is detected without power, the controller is damaged. If the voltage shows in normal with both lines, the fan motor is damaged.
4	E4	Ambient temperature sensor failure	Check the sensor is in open circuit or short circuit, and error code appears.	Check the indoor ambient temperature sensor is connected or not and measure the resistance whether is about 10K $\Omega$ (10K $\Omega$ at 25 $^{\circ}$ C). If the wire is connected well and the resistance shows in normal, it needs to replace the ADB controller board.

No	Fault Code	Fault	Cause	Remedy
5	E5	Indoor coil sensor failure	Check the sensor is in open circuit or short circuit, and error code appears.	Check the indoor temperature sensor (at the middle of U-type pipe of the evaporator) is connected or not and measure the resistance whether is about 10K $\Omega$ (10K $\Omega$ at 25°C). If the wire is connected well and the resistance shows in normal, it needs to replace the compressor controller.
6	E6	Outdoor coil temperature sensor failure	Check the sensor is in open circuit or short circuit, and error code appears.	Check outdoor temperature sensor (the outlet pipe of the condenser) is connected or not and measure the resistance whether is about 10K $\Omega$ (10K $\Omega$ at 25°C). If the wire is connected well and the resistance shows in normal, it needs to replace the compressor controller.
7	E7	Outdoor ambient temp sensor failure	Check the sensor is in open circuit or short circuit, and error code appears.	Check the outdoor temperature sensor is connected or not and measure the resistance whether is about 10K $\Omega$ (10K $\Omega$ at 25°C). If the wire is connected well and the resistance shows in normal, it needs to replace the compressor controller.
8	E8	PFC failure	The voltage regulator failure.	Replace the compressor controller.
9	E10	Communication failure between logic chip and display panel	No data communication between the logic chip and display panel	1、 The wire not connects well. 2、 The controller is damaged.
10	E11	Communication failure between logic chip and driver chip	No data communication between the logic chip and display panel over 60 seconds	Replace the controller.
11	E12	Overcurrent protection of the compressor hardware	The error code FO appears from compressor drive board IPM when it is considered as the hardware protection.	The controller is damaged.
12	E13	Compressor three-phase software overcurrent protection	Compressor U/V/W three-phase current is above 15A and the software overcurrent protection works.	The indoor coil of compressor is in short circuit or the controller is damaged.
13	E14	Compressor rotor locked protection	When the rotational speed of compressor is above 8000rpm or below 100rpm for 10s continuously, the rotor locked protection works.	Use the multimeter with AC power to detect the voltage with U/V/W. Any two-phase voltage is 5-150V that means the compressor is damaged with this transient voltage. If it is without this voltage that means the controller is damaged.

No	Fault Code	Fault	Cause	Remedy
14	E15	Compressor stall protection	When the difference between setting rotational speed and the actual speed of compressor is 300rpm and continues for 10s, the error code appears.	The controller is damaged.
15	E16	Under-voltage protection	The input voltage is below 160V.	Detect the input voltage. If the voltage is below 160V, check the power supply. If the input voltage is above 160V, it needs to replace the controller.
16	E17	Over-voltage input	The input voltage is above 265V.	Detect the input voltage. If the voltage is above 265V, check the power supply. If the input voltage is below 265V, it needs to replace the controller.
17	E19	The system failure(low refrigerant charge protection)	Compressor starts working and records the temp of indoor coil pipe (PTSAVE), running after 5 mins (PT) ; Cooling mode: PT<PTSAVE-2, the system is normal, otherwise it is abnormal.Heating mode: PT>PTSAVE+2, the system is normal, otherwise it is abnormal.	<ol style="list-style-type: none"> <li>1. Check the pressure of refrigerant, and the normal pressure runs not below 8psi.</li> <li>2. If the pressure is normal, check the connection between the indoor temperature-control coil and indoor coil pipe.</li> <li>3. When the temperature-control coil and indoor coil pipe are connected well and the pressure is normal, check the resistance of the indoor temperature-control coil whether is about 10K <math>\Omega</math> (10K <math>\Omega</math> at 25°C).</li> <li>4. If the situation mentioned above runs normally, it needs to replace the controller.</li> </ol>
18	E21	The exhaust temp is above 110°C.	Stop working, and will run again when the temp reached below 85°C.	<ol style="list-style-type: none"> <li>1. The ambient temp is too high and the condenser is blocked.</li> <li>2. The stop valve or the filter is blocked.</li> <li>3. The fault detect with the controller or the venting temperature-control coil checks the temp is in fault.</li> </ol>
19	E22	The temp of rooftop unit pipe is above 65°C.	Stop working, and will run again when the temp reached below 58°C.	<ol style="list-style-type: none"> <li>1. The outdoor ambient temp is above 55°C.</li> <li>2. The windward side of the condenser is blocked with dirt.</li> <li>3. The fault detect with the outdoor temperature-control coil or the controller checks the temp is in fault.</li> </ol>
20	E23	The temp of indoor pipe is above 65°C.	Stop working, and will run again when the temp reached below 58°C.	<ol style="list-style-type: none"> <li>1. The windward side of evaporator is blocked with dirt.</li> <li>2. The fault detect with the controller or the indoor temperature-control coil checks the temp is in fault.</li> </ol>
21	E24	The input AC of cooling or heating is above 7A.	Stop working, and will run again after 60s.	<ol style="list-style-type: none"> <li>1. The outdoor ambient temp is above 55°C.</li> <li>2. The controller is damaged.</li> <li>3. The compressor is in short circuit.</li> </ol>

No	Fault Code	Fault	Cause	Remedy
22	E25	The temp of IPM panel is above 95°C.	Stop working, and will run again when the temp reached below 80°C.	1. The ambient temperature is too high. 2. The controller is damaged.
23	E26	Phase loss protection	It detected one of U\W wires is in broken circuit and error code appears.	1. Check the connection between the controller and the wire U\W of compressor. 2. The controller is damaged.
<b>No Fault Code or Defrost Signal Troubleshooting</b>				
24	The cooling LED light is flashing.	The temp of indoor pipe is below 0°C.	Stop working and will run again when the temp is above 7°C.	1. The pressure of low pressure side of refrigerant is too low that leads to the evaporator frozen. 2. Use defrosting protection with the minimum air volume when the ambient temp is low. 3. The fault detect with the controller or the indoor temperature-control coil checks the temp is in fault.
25	The heating LED light is flashing.	Condenser defrosting works when runs in the heating mode. The temp of outdoor coil pipe is below -6 °C for a minute continuously.	The compressor stops working and the outdoor fan still work. Indoor fan works with anti-cool wind mode. Defrosting continues for maximum 10 mins or the temp of outdoor coil pipe is above 14°C.	1. Defrost at the normal work cycle. 2. When the windward side of the condenser is blocked and the ambient temp is below -5°C, it will shorten the work cycle. 3. The fault detect with the controller or the outdoor temperature-control checks the temp is in fault.
26	Not working	No digital display	The display panel is damaged or it is not powered by DC 12V.	Check the 12V communication wire and GND wire. If it is detected with 12V output, the display panel is damaged. If it is detected without 12V output, the controller is damaged.



## NOTE!

Please contact the supplier for further assistance, this equipment must be repaired by a professional.

## 10.0 Technical data

Model	CCA3000
Type	Inverter Compressor Air Conditioner
Cooling capacity	3000W
Input power cooling	1200W
Heating capacity-	3000W
Input power heating	1100W
Rated input voltage	220V-240V 50/60Hz
Maximum current	7A
IP Rating	IP55
Rated cooling input current	5.5A
Rated heating input current	5A
Max pressure (High)	3.9Mpa
Max pressure (Low)	1.7Mpa
Circuit protection	25mm <sup>2</sup> Copper and length not more than-8m
Cable section and length	25mm <sup>2</sup> Copper and length not more than-8m
Airflow	550m <sup>3</sup> /h
Applicable temperature	-2°C ~55°C
Refrigerant	R410a
Refrigerant quantity	630g
Dimensions Lx Wx H	1107x718x225mm
Main unit Net/Gross weight	31Kg/37Kg
Accessories Net/Gross weight	4.8Kg/6Kg

### NOTE!

To continuously improve our products, we reserve the rights to change some specifications without further notice, please check the data plate.

## 11.0 Wiring diagram

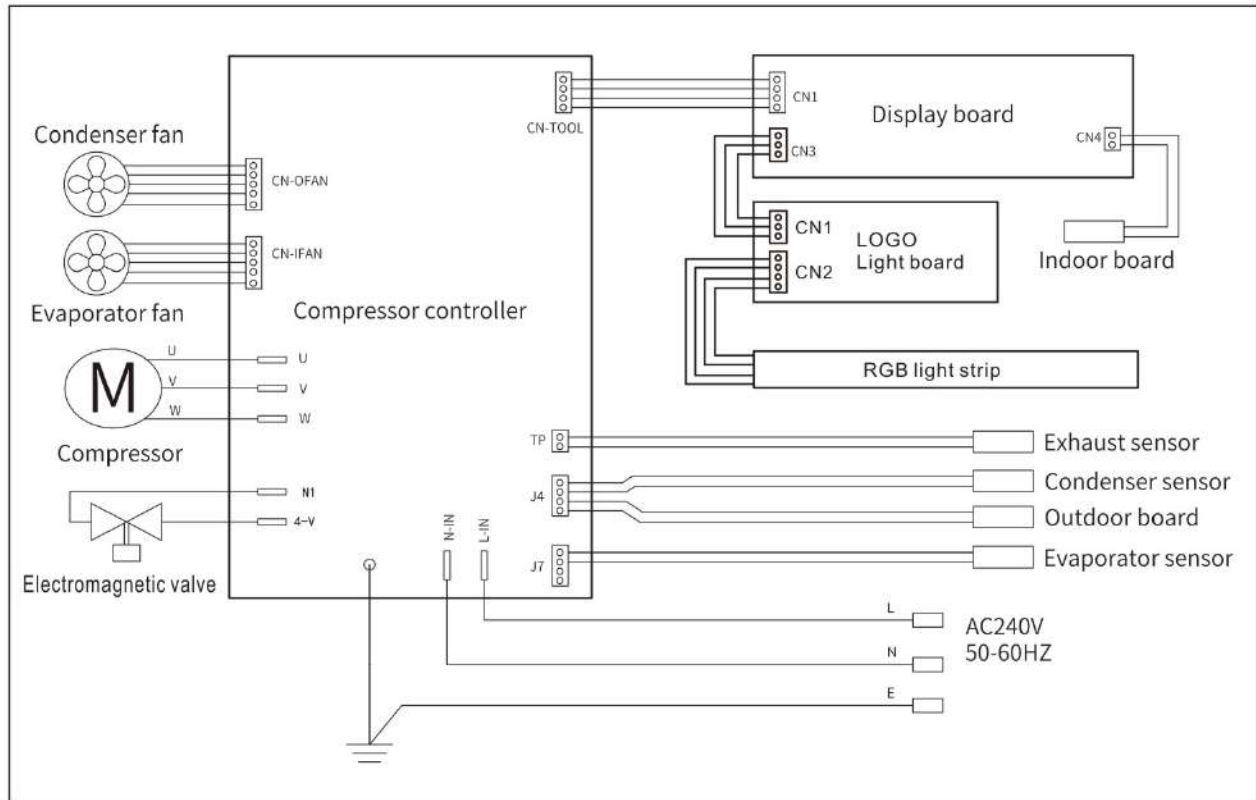

## 12.0 Parts list

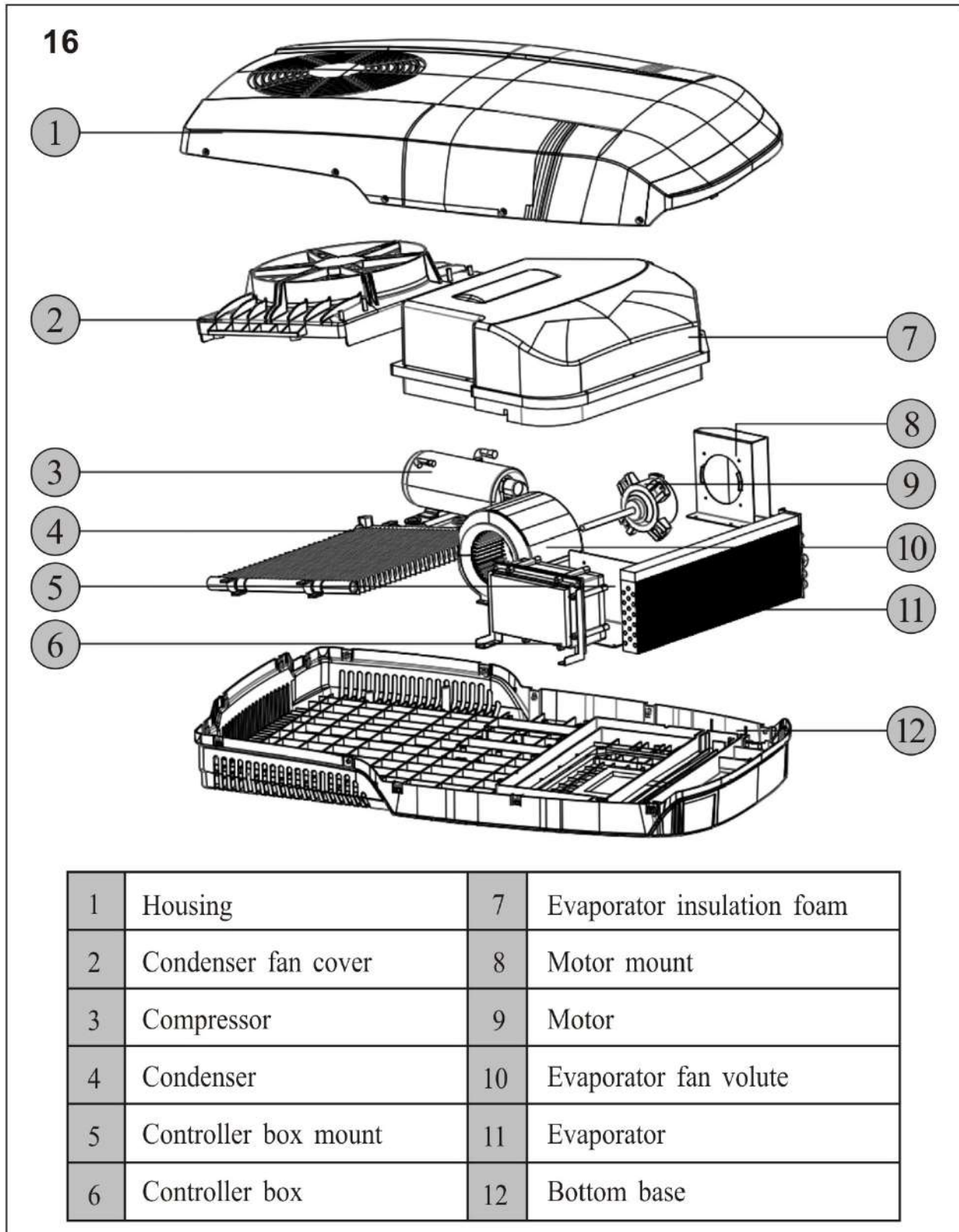

17

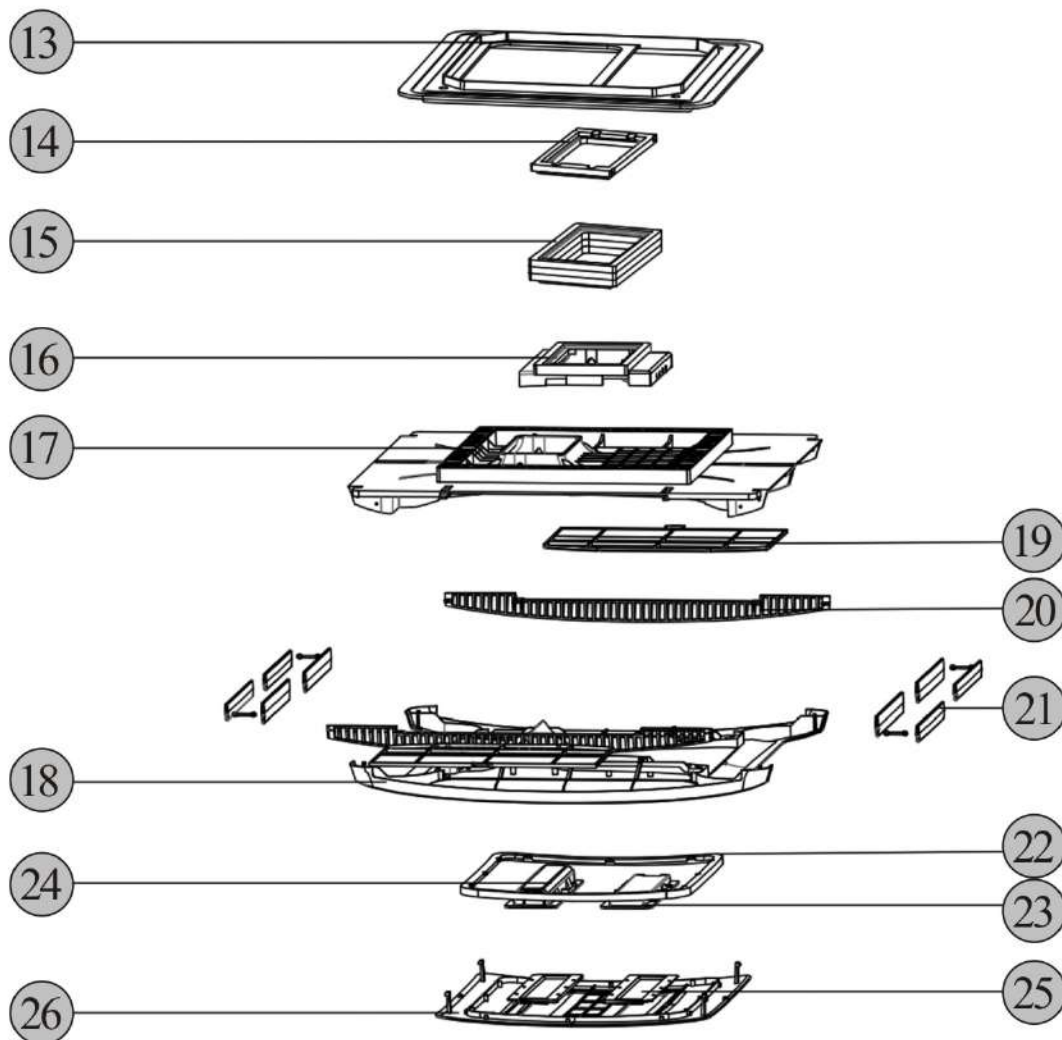

13	Roof mounting frame	20	Air inlet grid
14	Air duct block-top	21	Blade
15	Air duct block-middle	22	LED light cover
16	Air duct block-bottom	23	Logo base
17	Air diffuser base	24	Control panel base
18	Air diffuser	25	Control panel
19	Air filter	26	Control panel cover

## 13.0 Warranty

When you acquire or fit a MyCOOLMAN Air Conditioner you have the peace of mind in knowing that it is backed by a comprehensive 3 year warranty against defects in materials and workmanship plus 2 years (parts only) on the compressor.

The MyCOOLMAN warranty is provided in addition to any rights you may have under the Australian Consumer Law. All claims under this warranty should be made by returning the product to the place of purchase at your expense, with the detail of the fault, proof

of purchase and fitment details. If we determine that a MyCOOLMAN product is defective in materials or workmanship during the warranty period, we will either repair or replace the unit.

This warranty does not apply to failure or damage to a MyCOOLMAN product caused by incorrect or faulty fitment, accidental or intentional damage, failure of other products, incorrect application, incorrect voltage, environmental damage, operation of the product outside of its environmental and technical specifications, or repair or modification carried out by anyone other than an authorised repairer. Our goods come with guarantees that cannot be excluded under the Australian Consumer Law. You are entitled to a replacement or refund for a major failure and compensation for any other reasonably foreseeable loss or damage. You are also entitled to have the goods repaired or replaced if the goods fail to be of acceptable quality and the failure does not amount to a major failure.

# MYCOOLMAN

Designed in Germany, made in China for

**LEISURE-TEC** Australia Pty Ltd  
50 Metrolink Circuit  
Campbellfield, VIC 3061  
Australia

