



## FRESH WATER PUMP

### FEATURES & BENEFITS

- Up to 3.0 GPM
- Self priming
- Factory fitted check valve
- Run dry safe
- Quiet operation
- On-demand use
- Industry Standard mounting pattern
- Rubber mounting base
- Internal bypass technology reduces cycling
- 16 AWG, 9.4" long leads
- Encapsulated switch

### PUMP

- Max Recommended Temperature  
140°F (60°C) Max.
- Priming Capabilities  
6 feet (1.8 m) suction lift
- Inlet/Outlet Ports  
1/2"-14 MNPT
- Weight  
4.1 lbs (1.90 kg)

### Standard Accessories

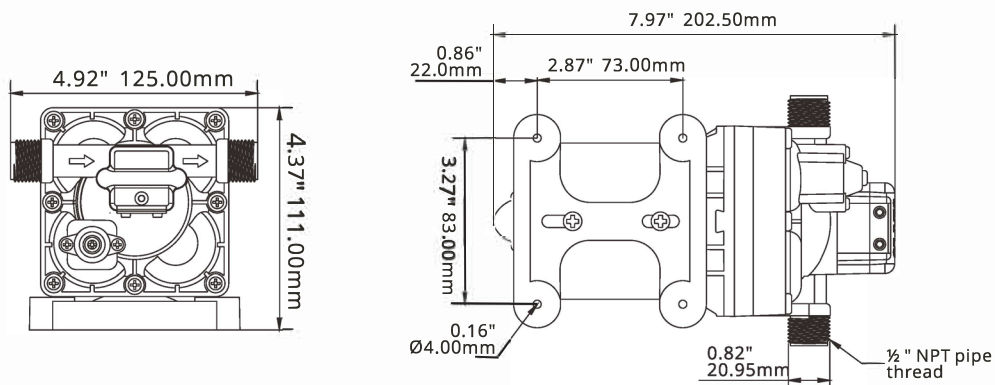

### STANDARD PUMP CONFIGURATIONS

Model	Voltage	Control Type	GPM/LPM	PSI/BAR	Max Draw(A)	Valves	Diaphragm	Ports	Wire Connections
RV1-030-055-42	12V DC	Switch & By pass	3.0/11.3	55/3.8	6.0	EPDM	Santoprene	1/2"-14 MNPT	2-Pin/Leads
RV2-030-055-42	24V DC	Switch & By pass	3.0/11.3	55/3.8	4.0	EPDM	Santoprene	1/2"-14 MNPT	2-Pin/Leads